

USER MANUAL

Before using the TV, please read this manual thoroughly and retain it for future reference.

ENGLISH

Contents

First-Time Use

Using the E-Manual.....	4
Home Screen.....	5
Connecting to the Internet.....	7
User Account.....	8
Selecting Inputs.....	9
Using Voice Service on the TV.....	10

Enjoy Live TV

Channel Scan.....	13
Live Menu.....	14
Channel Edit.....	16
Programme Info.....	19
Programme Guide (EPG).....	20
Programme Recording (PVR).....	22
Reminder.....	25
Timeshift.....	25
HbbTV.....	27
CI+ Module Settings.....	27

Benefits of Smart TV

Voice Service Setup.....	29
Using Apps.....	32
VIDAA Kids.....	34
Using the VIDAA ART.....	36
Using the Browser to Search the Internet.....	39
Using the Mobile App.....	40
Use Energy Saving Functions.....	40

Connecting to External Devices

Connection Guide.....	42
Remote & Accessories.....	42
Connecting Bluetooth Devices.....	47
Screen Sharing.....	48
Content Sharing.....	49
Using AirPlay and HomeKit.....	50
Connecting a Set Top Box.....	51
Connecting a Blu-ray or DVD Player.....	52
Connecting USB Devices.....	52
Connecting Audio Visual (AV) Devices Input Sources.....	53
Connecting a PC.....	54

Contents

Connecting Headphones.....	54
Connecting Speakers or Other Audio Receivers.....	55
Connecting a Digital Audio System with ARC/eARC.....	55

Settings Overview

Picture.....	57
Sound.....	61
Network.....	65
System.....	67
Support.....	71
Using Parental Control.....	73
Reset to Factory Default.....	74

Entertainment

Game.....	75
Sports.....	77
Media.....	78
SoundBar Settings.....	80
WiSA Speaker Settings.....	81
Karaoke.....	82

Accessibility Features

Subtitle Setup.....	84
Voice Guide.....	84
Audio Type Setup.....	84
Dialogue Enhancement.....	85
Accessibility Menu Setup.....	85
Accessible Guide.....	85
Magnification.....	86

Troubleshooting

FAQ.....	87
Troubleshooting Guide.....	95
Picture Issues.....	97
Sound Issues.....	98
Channel and Broadcast Issues.....	100
Network Issues.....	101
App Issues.....	102
Remote Control Issues.....	103
External Device Connection Issues.....	103
HDMI & CEC Issues.....	105

Contents

Voice Service Issues.....	106
Media Files Issues.....	106
Other Issues.....	107

First-Time Use



Using the E-Manual

View the embedded E-Manual that contains information about your TV's key features.

Disclaimer:

- Instructions and images throughout this manual are only for reference and may differ from the actual product.

Launch the E-Manual

Press  button on your remote control and select  **Settings** > **Support** > **E-Manual**.

Note:

- The black background icon indicates the button on the remote control.
- The grey background icon indicates the icons on the TV or your device screen.

Use the buttons in the E-Manual

E-Manual on TV

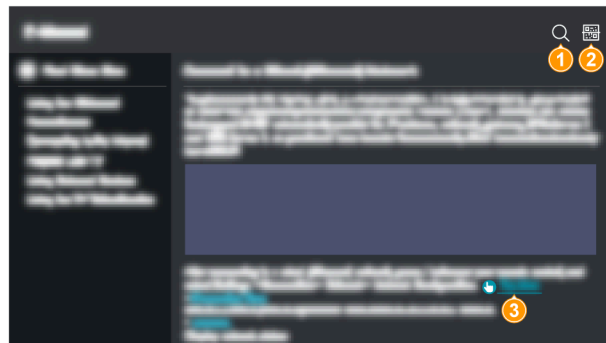

Search

Search for the product feature information, the E-Manual will provide all the titles and content that contains the search information.

QR Code

Scan the QR Code with your smart device to open the E-Manual on your device.

Try Now button

Select Try Now, this will guide you to the corresponding TV menu for trying the function.

First-Time Use

E-Manual on mobile device

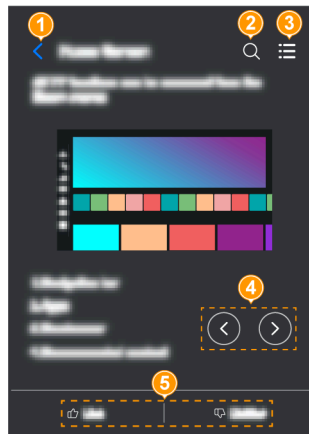

- 1 Select to return to the home screen of E-Manual
- 2 Search for the product feature information
- 3 Select to display the outline of E-Manual
- 4 Page up/down
- 5 Feedback

Home Screen

All TV functions can be accessed from the Home screen.

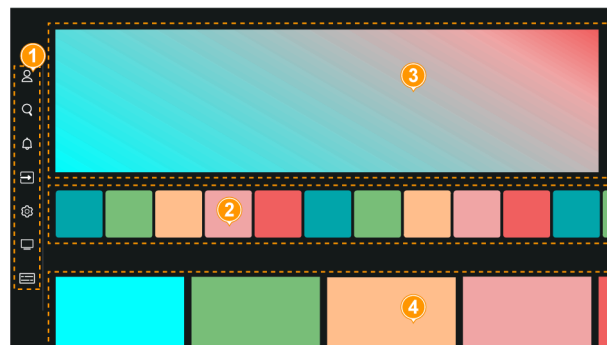

- 1 Navigation bar
- 2 Apps
- 3 Top banner
- 4 Recommended content





Note:

- Indicators or icons may vary depending on models/countries/regions.

First-Time Use

Display the Home Screen

Press  button on your remote control to enter the Home screen.

To choose input, press  /  button on your remote control or use the navigation buttons to move the focus to the  **Input** icon on the side of the screen, press  button to enter and select your desired input source.

Use the Navigation Bar

The navigation bar refers to indicators and icons on the side of the Home screen.

Note:

- Indicators or icons may vary depending on models/countries/regions.

Account

A VIDAA account provides all the best features of your Smart TV and ensures that all services are kept up to date.

For more information about VIDAA account, please refer to [First-Time Use > User Account](#) in this manual.

Search

Search the content you want.

Notification

Allow pop-up notifications to appear for useful information and events that occur with your TV, including: **Advertising, New Arrivals, Warnings and Legal Statements, System Messages and Alexa Notification.** You can enable/disable each of these notifications at Settings in the notification centre.

You can view the list of event messages generated by the TV.

To delete all notifications, select **Clear All**.

Note:

- The Alexa Notification may not be applicable in some models/countries/regions.

Input

Select the input source depending on the device you have connected to your TV.

Settings

Manage TV configuration.

Live TV

Quick access to Live TV.

Guide

Quick access to Guide. For more information, please refer to [Enjoy Live TV > Programme Guide \(EPG\)](#) in this manual.

Use the Shortcuts

You can add websites to the Home screen to have quick access to them for your convenience.

First-Time Use

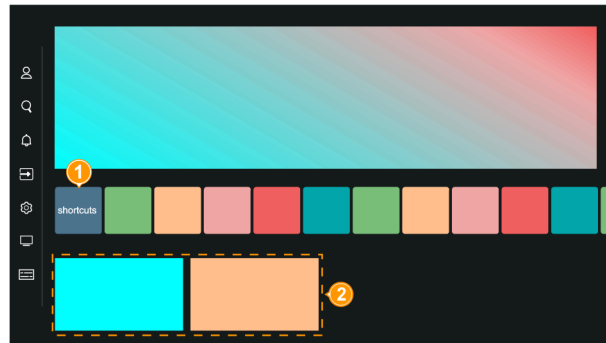

1 Shortcuts

2 Added websites

Add and remove webpages

1. In Browser, visit a website you would like to add on the Home screen.
2. Use the D-pad to move the focus to the  icon in the top of the Browser navigation bar.
3. Select **Add** and this webpage will appear in the Shortcuts on the Home screen.

Note:

- To remove webpages from Shortcuts, move the focus onto the shortcut page, then press and hold the  button on your remote control.

Connecting to the Internet

To get access to the Internet using a wired connection or connecting to an available wireless network.

Connect to a Wired (Ethernet) Network

To get access to the Internet using a wired connection, it is recommended to use a modem or router that supports Dynamic Host Configuration Protocol (DHCP). Modems and routers that support DHCP automatically provide the IP address, netmask, gateway, DNS Server 1 and DNS Server 2, so you do not have to enter them manually. Most home networks already have DHCP.



1 IP Sharer (Router) with DHCP server

2 External Modem (ADSL/VDSL/Cable TV)

After connecting to a wired (Ethernet) network, press  button on your remote control and select  **Settings > Connection > Network > Network Configuration**.

First-Time Use

- **Connection Type**

Choose a wired (Ethernet) network connection to access the Internet.

- **Ethernet**

Display network status.

- **IP Settings**

In **IP Version**, you can select from IPv4 and IPv6. When IPv4 is selected, the IP address, netmask, gateway, DNS Server 1 and DNS Server 2 will be automatically defined, or you can configure them manually for your network connection. When IPv6 is selected, all information is automatically defined.

 **Related information**

[Network](#) on page 65

[Network Issues](#) on page 101

[My TV cannot connect to the network.](#) on page 89

Connect to a Wireless Network

To connect to an available wireless network, make sure that you turn on your wireless router and have the wireless router's SSID and password before attempting to connect.



To get access to the Internet using a wireless connection, press  button on your remote control and select

 **Settings > Connection > Network > Network Configuration.**

- **Connection Type**

Choose a wireless network connection to access the Internet.

- **Refresh**

If no wireless router is found, select **Refresh**.

- **Advanced Settings**

Configure the advanced wireless network settings for the TV.

- **Add**

If no wireless router is found, select **Add** and enter the network name in the SSID to add a wireless network.

 **Related information**

[Network](#) on page 65

[Network Issues](#) on page 101

[My TV cannot connect to the network.](#) on page 89

User Account



Sign into your VIDAA account and create multiple profiles to receive personalised content according to your account preferences.

First-Time Use

Create a new account



If you do not have a VIDAA account, create a new one to enjoy the best features of your Smart TV.

Before creating a new account, make sure your TV is connected to the network. For more about network settings, please refer to [First-Time Use > Connecting to the Internet > Connect to a Wired \(Ethernet\) Network](#) or [Connect to a Wireless Network](#) in this manual.

1. After the network is connected, press  button on your remote control and select  **Account** icon in the navigation bar on the Home screen.
2. Select **Create Account** on screen (or select **Email Create Account** for some countries/regions).
3. Enter your E-mail address and password.
4. Follow the instructions on your TV to finish the process of creating an account.

Sign into an account

Before signing into your VIDAA account, make sure your TV is connected to the network. For more about network settings, please refer to [First-Time Use > Connecting to the Internet > Connect to a Wired \(Ethernet\) Network](#) or [Connect to a Wireless Network](#) in this manual.





1. After the network is connected, press  button on your remote control and select  **Account** icon in the navigation bar on the Home screen.
2. Register your device to your VIDAA Account. After entering your E-mail and password, select **Sign in**.
3. You can create a profile and give it a name.

If you forget your password and need to change the password, select **Forgot Password?** input your E-mail address and verification code, then create a new password.







Selecting Inputs

Access to connected external devices including wireless connected devices.

Switch between external devices connected to the TV

1. Press  /  button on your remote control or press  button to move the focus to the  **Input** icon on the side of the Home screen, press  button to enter.
2. Select your desired input source.

Edit the name of input sources

1. Press  /  button on your remote control or press  button to move the focus to the  **Input** icon on the side of the Home screen, press  button to enter.
2. Move the focus to an input source and press  button on your remote control to edit.

Note:



- Some input sources cannot be renamed.

Set the input source as default start page



You can set the input source to display every time the TV is turned on. For specific information please refer to [Default Start Page](#).

First-Time Use



Set a quick access to input sources

You can use the  /  /  button on the remote control as a quick access to the desired input.

Customise or re-customise the button

1. Press and hold the  /  /  button on the remote control.
2. Select an input you desire.
3. Choose **Save** to confirm the operation.



Note:

Remote control with the  /  /  button is only available in some models/countries/regions.

Using Voice Service on the TV

Select the voice service

To access the Voice Service and select a voice assistant to help control your TV, you can choose one of the following ways:

- Press  button on your remote control.
- Press  button to select  **Settings** icon and select **System > Voice Service**.

Note:

- Before using Voice Service, please pair the Bluetooth remote control with your TV first.
- To use this function, connect the TV to the network.
- Voice Service feature may not be applicable in some models/countries/regions.
- Voice Service only supports some languages.

Search for content or operating the TV with your voice

You can interact with the voice assistant to help you find your favourite movies, search TV programmes, play music or control your TV.





Use microphone button on the remote control

Press and hold the  button on your remote control, say a voice command while holding the microphone button, then release the button.



First-Time Use



Notice:

- Remote control with  button is only available in some models/countries/regions.
- For remote control without the microphone button, download and install the app on your mobile device at  >  **Settings** > **Connection** > **Mobile App Download**. Press the microphone icon in the app.
- If you select VIDAA Voice as your voice assistant, you can find more detailed recommended commands at  **Settings** > **System** > **Voice Service** > **VIDAA Voice** > **See All Commands**.
- To use this function, End User License Agreement and corresponding Smart feature privacy policy/terms and conditions may be required to be agreed to.

Hands-Free Mode: Use the built-in microphone on the TV (only for the TVs with a built-in microphone)

Interacting with Alexa or VIDAA Voice by just using your voice, all hands-free.

Before using Hands-Free Mode, you need to follow these steps first:

1. Connect your TV to the network
2. Sign into your VIDAA Account at  >  **Account**. (For more information about how to sign into the VIDAA Account, please refer to [First-Time Use > User Account](#) in this manual.)
3. Turn on the built-in microphone control button on the TV. (For the location of the built-in microphone control button on the TV, please refer to the printed manual or quick setup guide included with the TV.)

How to use Hands-Free Mode

After the Alexa or VIDAA Voice setup has been completed, say "Alexa" or "Hey VIDAA" to call up the voice assistant to get started.

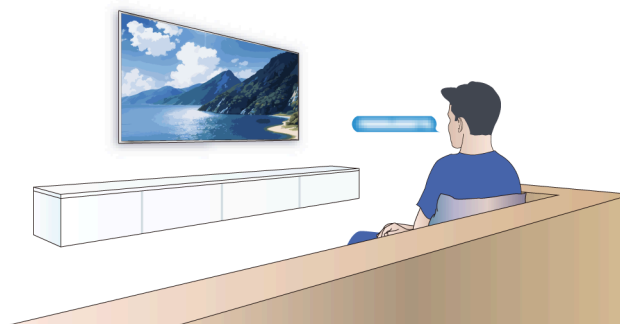



Note:

- The Hands-Free mode function may not be applicable in some models/countries/regions.
- The setup steps may vary. Please refer to the specific product.
- This feature requires Alexa built-in service.
- This function is available only if Voice Service is set to Alexa or VIDAA Voice.
- Power consumption will increase when the built-in microphone is enabled.

Voice service other issues

If you want to turn on your TV with Alexa-enabled devices (e.g. Echo, Echo show) or Google Home devices (e.g. Google Home, Google Nest Hub), please:

First-Time Use

- Turn on **Wake on LAN** and **Wake on Wireless Network** at  >  **Settings** > **Connection** > **Network**.
- Make sure your TV and Alexa-enabled devices/Google Home devices are connected to the same network environment.

Note:

- Only Alexa (Alexa skill is enabled) and Google Smart Home Service support turning on your TV with Alexa Echo or Google Home.

 **Related information**

[Voice Service Setup](#) on page 29

[Connect to a Wired \(Ethernet\) Network](#) on page 7

[Connect to a Wireless Network](#) on page 8

Channel Scan





You can scan for channels automatically or manually.

Note:

- Only for the models with tuners.

Auto Scan

Automatic channel scan.

1. Press  /  button on your remote control and select **TV**.
2. In Live TV, press  /  /  button and select **All Settings > Channel > Auto Scan**.

If no TV channels were saved before, you will be prompted to do a channel scan.

Satellite

- **Single satellite:** You can use single satellite if you only have one satellite installed.
- **DiSEqC:** You can choose DiSEqC if you have DiSEqC equipment. Up to four satellites in DiSEqC 1.0 mode can be installed.

If you are using a motorised aerial, you can use DiSEqC 1.2 mode.

- **Unicable:** If your home is equipped with Unicable satellite distribution, you should use this option.

Please make sure that you know the Unicable band and frequency to be used. The information should be available on the equipment or the landlord can provide it.

Aerial

- **Channel:** Select from **All Channels** or **Free Channels**. This option may not be available depending on countries/regions/operators.
- **Scan Mode:** Select from digital channels only (DTV), digital and analogue channels (DTV+ATV) or analogue channels only (ATV).

If you receive DVB-T or DVB-T2 signal, you can use DTV.

- **LCN:** Switch on/off LCN (Logical Channel Number).

Please note that some operators restrict manual changes to the channel order. If you switch off LCN, then the channel list can be edited after channel scan.

This function may not be applicable in some models/countries/regions.

Cable

- **Channel:** Select from **All Channels** or **Free Channels**. This option may not be available depending on countries/regions/operators.
- **Scan Mode:** Select from digital channels only (DTV), digital and analogue channels (DTV+ATV) or analogue channels only (ATV). For some countries/regions, only ATV is available.
- **LCN:** Switch on/off LCN (Logical Channel Number).

Please note that some operators restrict manual changes to the channel order. If you switch off LCN, then the channel list can be edited after channel scan.

This function may not be applicable in some models/countries/regions.

Note:

Enjoy Live TV

- Satellite/aerial/cable function may not be applicable in some models/countries/regions.

Manual Scan

Manual scan channels for DTV or ATV.

1. Press **INPUT** / **TV** button on your remote control and select **TV**.
2. In Live TV, press **LIST** / **LIST** / **MENU** button on your remote control and select **All Settings > Channel > Advanced Settings > Manual Scan**.

Note:

- Services may vary depending on models/countries/regions.

Live Menu

You can obtain quick access to the channel list, favourite channel list or use relevant features with ease when watching TV programmes.

Note:

- Only for the models with tuners.

Display Channel List

In Live TV, press **OK** / **CHLIST** button on your remote control to display the Channel List menu.

Alternatively, in Live TV, press **LIST** / **LIST** / **MENU** button on your remote control and select **Channel List**.

Note:

- In some special cases, Channel List menu cannot be displayed by pressing **OK** button. You could try to press **EXIT** button first or turn off HbbTV function, then try again.

Learn about channel list sub-menu

In Live TV, press **OK** / **CHLIST** button on your remote control and press **←** button.

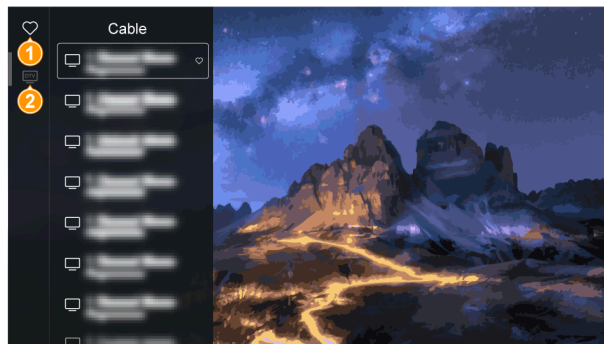

1 FAV

Press and hold **OK** button to display favourite lists 1 to 4.

2 TV List

Enjoy Live TV

Press and hold **OK** button to display Live TV channel categories, such as **Cable** and **Aerial**.



Note:

- The sub-menu options may vary depending on models/countries/regions.

 **Related information**

[Edit Channel List](#) on page 16

Channel List Auto Update

In Live TV, press //**MENU** button on your remote control and select **All Settings > Channel > Advanced Settings > Channel List Auto Update**.

Allow your TV to automatically update the channel list from the content provider.

Learn about the On-Screen Menu

Launch the on-screen menu

In Live TV, press //**MENU** button to access the on-screen menu.

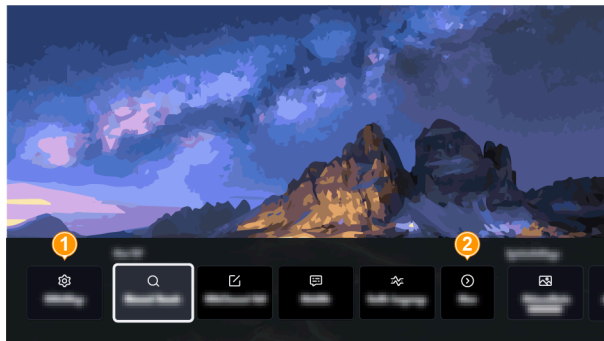

All Settings

Set up Picture, Sound, Channel, Connection, Accessibility, System and Support.

More

Expand the menu to display more features.

Note:

- The menus displayed will vary depending on models/countries/regions.

Enjoy Live TV

Edit the on-screen menu

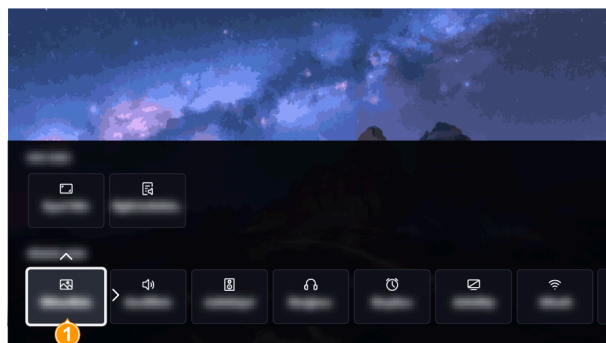

1 Edit the item of the on-screen menu

1. Move the focus to the last item of the on-screen menu to select Edit.
2. Move the focus to an item you want to edit, press the **OK** button on the remote control, and use the D-pad to relocate.
3. Press **OK** button to finish.

Alternatively:

1. Move the focus to an item you want to edit, long press the **OK** button on the remote control, and use the D-pad to relocate.
2. Press **OK** button to finish.

Related information

[Programme Guide \(EPG\)](#) on page 20

[Programme Recording \(PVR\)](#) on page 22

[HbbTV](#) on page 27

[Subtitle Setup](#) on page 84

Channel Edit

Manually edit the channel list or favourite channel list to your preference.

Note:

- Only for the models with tuners.

Edit Channel List

Before you can edit the channel list, Channel Scan must be completed first.

In Live TV, press **□/≡/MENU** button on your remote control and select **Edit Channels**.

Alternatively, in Live TV, press **□/≡/MENU** button on your remote control, select **All Settings > Channel > Channel Edit**, then select a Live TV channel category such as Aerial or Cable.

Manage the channels

In channel edit page, move or delete the channel in focus or press **OK** button on the selected channel, then a checkbox will appear. You can select multiple channels at the same time to move or delete.

Enjoy Live TV

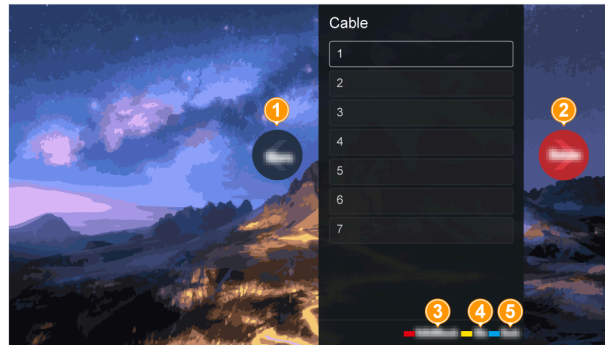

1 Move

Press button to move the selected channel.

Moving the channels could be restricted by the operator. If you want to be able to move channels, it is not recommended to choose an operator during channel scan, also LCN should be set to Off.

2 Delete

Press button to delete the selected channel.

3 Deleted channels

Press [RED] button, or press / button to display the colour menu and select RED to enter the list of deleted channels. Press button to restore the deleted channel.

4 Filter

Press [YELLOW] button or press / button to display the colour menu and select YELLOW, the filter screen will pop up. Press button to select options, the channel list can then be updated.

5 Search

Press [BLUE] button or press / button to display the colour menu and select BLUE to search for a channel.

Export the channel list to USB

The current channel list can be exported to a USB storage device.

In Live TV, press / / button on your remote control and select **All Settings > Channel > Channel Edit > Export to USB**.

Import the channel list from USB

Previously exported channel lists can be imported via a USB storage device.

In Live TV, press / / button on your remote control and select **All Settings > Channel > Channel Edit > Import from USB**.

Related information

[Channel Scan](#) on page 13

Enjoy Live TV

Edit Favourite Channel List

Before you can edit the favourite list, Channel Scan must be completed first.

Add a channel to a favourite list

You can add channels from various reception types to the favourite list.

1. In Live TV, press **OK/CHLIST** button on your remote control to display the channel list.
2. Select the channel you want to add to the favourite list, press and hold **OK** button, the channel will be added to the last visited favourite list automatically, a heart-shape icon will appear next to the added channel.

Remove a channel from favourite list

1. In Live TV, press **OK/CHLIST** button on your remote control.
2. Select the channel you want to remove from the favourite list, press and hold **OK** button, the channel will be removed.

Edit a favourite list

In Live TV, press **≡/≡/MENU** button on your remote control and select **All Settings > Channel > Channel Edit**, then select **FAV1-FAV4**.

You can add, move, or remove favourite channels.

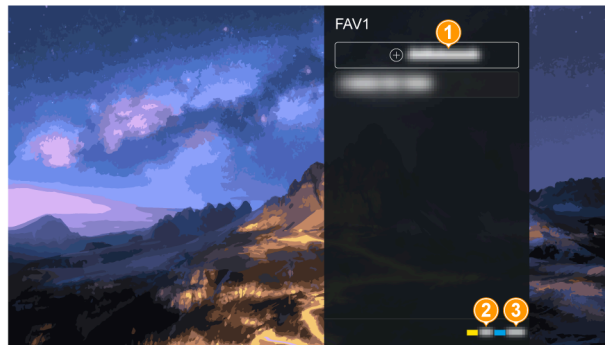

1 **+** Add channels

Select **+** Add channels to add the selected channel to the favourite list.

2 **Filter**

Press **[YELLOW]** button or press **[COLORS]/123** button to display the colour menu and select YELLOW, the filter screen will pop up. Press **OK** button to select options, the favourite channel list can then be updated.

3 **Search**

Press **[BLUE]** button or press **[COLORS]/123** button to display the colour menu and select BLUE to search for a favourite channel.

• **Move**

Select a channel in a favourite list, then press **←** button to move it.

Enjoy Live TV

- **Remove**

Select a channel in a favourite list, then press  button to remove it.

 **Related information**

[Channel Scan](#) on page 13

Programme Info

Mini bar

While switching channel, the mini bar will appear for a few seconds.

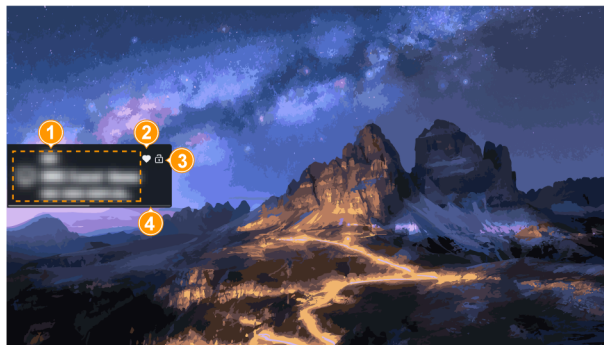

- ① Channel logo, Channel number, Channel name, Current programme name
- ② Favourite channel indicator
- ③ Locked channel indicator
- ④ Current programme progress

Info bar

While watching TV programmes, press  /  /  /  button to display the programme info bar.

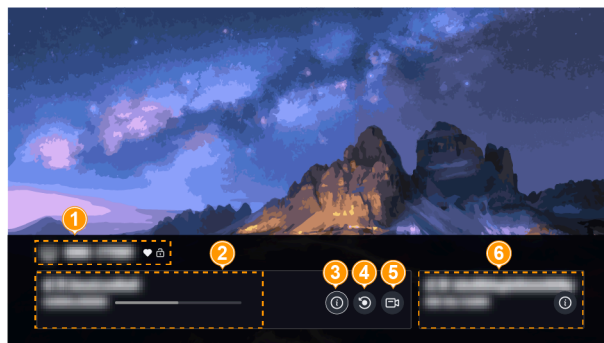

- ① Channel logo, Channel number, Channel name, Favourite channel indicator, Locked channel indicator

Enjoy Live TV

- 2 Current programme
- 3 More information button
- 4 Timeshift button
- 5 PVR button
- 6 Next programme

Note:

- The remote control buttons may vary depending on models/countries/regions.
- The image is only for reference and may differ from the specific product.
- In some special cases, ◀ / ▶ button may not work, you could try to press EXIT button first or turn off HbbTV function, then try again.

Related information

[Timeshift](#) on page 25

[Programme Recording \(PVR\)](#) on page 22

[Using Parental Control](#) on page 73

Programme Guide (EPG)

The Guide (EPG) provides a convenient way to check TV programmes for the upcoming 8 days. The information displayed by the Guide (EPG) is made available by the commercial television networks for digital channels only. The Guide (EPG) also provides a simple way to record your favourite programmes and a reminder function, which can switch channels automatically at scheduled times, so that you will not miss programmes of interest. The availability and amount of programme information will vary depending on the broadcaster.

Note:

- The Guide (EPG) function is only available for digital channels, analogue channels are not supported.

Launch the guide

In Live TV, press GUIDE / EPG button, or press [Grid] / [List] / MENU button and select **Guide (EPG)** to display programme guide.

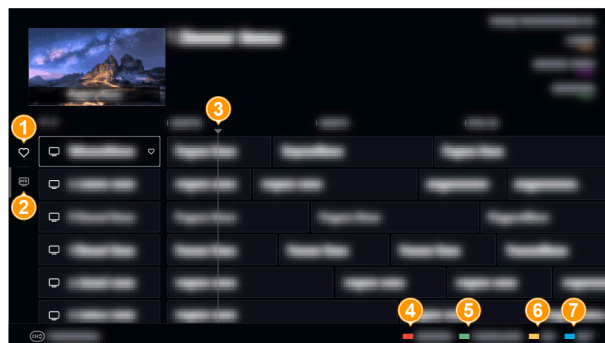

- 1 FAV

Enjoy Live TV

Press and hold  button to display favourite lists 1 to 4.

2 TV List

Press and hold  button to display Live TV channel categories, such as Cable and Aerial.



3 Current time and current programme

The vertical line indicates all programmes that are on now. Pressing the  button on any programme on the vertical line will directly switch to the programme.

4 Scheduled

In Guide (EPG), press  [RED] button or press  /  button to display the colour menu and select RED. This will display a list of scheduled reminders and recordings.



5 Programme Colour

In Guide (EPG), press  [GREEN] button or press  /  button to display the colour menu and select GREEN. Use the colours to indicate different genres in the Guide (EPG) for quick and easy viewing.

Note:

- This function may not be applicable in some models/countries/regions.

6 24h-





In Guide (EPG), press  [YELLOW] button or press  /  button to display the colour menu and select YELLOW to select programmes of the previous day.

7 24h+

In Guide (EPG), press  [BLUE] button or press  /  button to display the colour menu and select BLUE to select programmes of the next day.

PVR/Reminder in Guide menu

• PVR/Reminder

In Guide (EPG), press  /  button to select the channel. Press  /  button to select programme based on the time schedule.



Press  button to select **PVR** or **Reminder**.

For more information, please refer to [Enjoy Live TV > Programme Recording \(PVR\)](#) or [Enjoy Live TV > Reminder](#) in this manual.

Note:

- The PVR function may not be applicable in some models/countries/regions.

Programme guide auto update

Press  /  /  button on your remote control and select **All Settings > Channel > Advanced Settings > Programme Guide Auto Update**.

TV will automatically update the Programme Guide data overnight while in stand-by mode.

Programme Recording (PVR)

The PVR function allows you to easily record digital television content for later viewing.

Read before recording programmes

- To use PVR, you must connect a storage device for recording. PVR will not function if a data storage device has not been connected.
- The format of the storage device can be NTFS or FAT32. The storage space of your device should be no less than 2GB (for 15 minutes high-definition video). It is strongly recommended to use a USB mobile hard disk drive instead of a USB flash drive as the storage device.
- If the transfer rate of your hard disk is too slow, a pop-up notice will be displayed. In this case, you will need to use another disk with higher speed.
- PVR is only available for digital channels, PVR is not supported for analogue internet channels.
- Some broadcasters may restrict the recording of programmes.
- If a recording is made from a locked channel, the system PIN will need to be input to playback the recorded content.
- Some channel-related configuration may conflict with background recording. In this case, a reminder window will pop up.
- If the recording time to the USB storage device is less than 5s, no data will be saved.
- After programming the TV to record digital broadcasting, do not disconnect the power plug before recording starts.
- If video or audio recording fail due to malfunction of the TV or poor reception, no compensation shall be paid.
- Recorded programmes saved in the USB storage device can only be viewed on this TV. They cannot be viewed when connected to another TV (including the same model of TV), a PC, or other devices.
- The PVR function may not be applicable in some models/countries/regions.















Related information

[Connecting USB Devices](#) on page 52

Recording

Schedule recording

There are several ways to use PVR.

- In Live TV, press  /  /  button and select **PVR**.
- In Live TV, press  /  /  /  button to display the info bar and choose .
- In Live TV, press  /  button, or press  /  /  button and select Guide (EPG) to display programme guide. Select a programme and choose **PVR**.
- If your remote has  button, press it and use D-pad to select  to set up PVR.

Enjoy Live TV

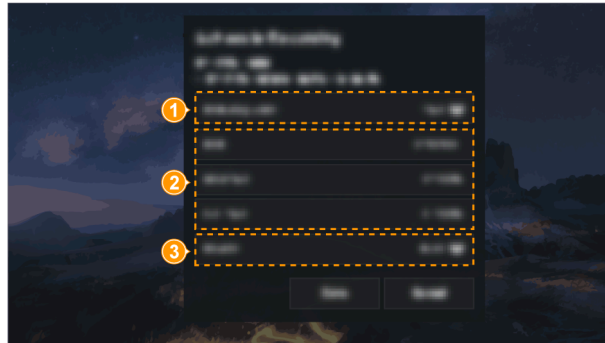

1 Recording mode

Select recording mode. Time mode sets the actual start and stop time, Manual Stop mode sets the actual start time but the user can stop at any time, Programme mode follows the broadcasters schedule.

2 Date, Start time, End time

3 Repeat

Define if the programme should be recorded once or at regular intervals.

Standby recording

If you press the power button during recording, your TV will go into standby mode, but the recording process will continue. If you press the power button again to wake up the TV, the recording process will not be affected. After recording, the recorded file will be automatically saved to the attached USB disk.

Background recording

When you switch to an App or another source (e.g. HDMI) during recording, the recording process will continue. When the recording has completed, the recorded programme will be automatically saved to the attached USB disk.

If you want to manually stop recording, press **INPUT** / **TV** button on your remote control and select **TV** to switch back to the channel that is currently being recorded, then press **◀** / **▶** button and select **□** on-screen to stop.

Learn about the recording control bar

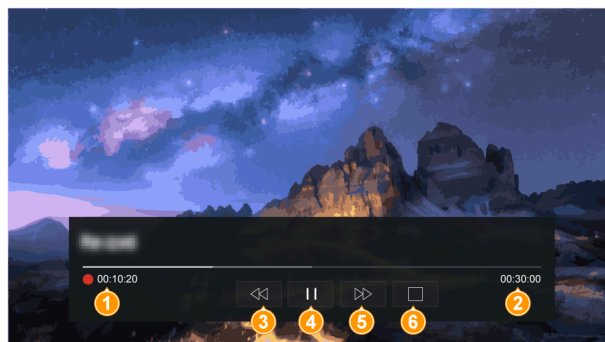



Enjoy Live TV

- 1 Recording time
- 2 Total time
- 3 Rewind
- 4 Pause / Play
- 5 Fast forward
- 6 Stop

Note:

- The PVR function may not be applicable in some models/countries/regions.
- Buttons on remote control will vary depending on models/countries/regions.

Recording related settings

Press  /  /  button on your remote control and select **All Settings > Channel > Recording & Time Shift**.

• Setup

When you connect more than one USB storage device to the TV, the one selected in **Setup** is initialised for starting recording. The recorded programme will be saved in the selected storage device.

• Start in advance/Delay Ending

Set pre-recording/post-recording time to allow for programme schedule deviation.

• Format Hard Disk

Format the external USB disk to support PVR. If any problems occur while operating the hard drive, it may be possible to eliminate them by formatting the hard drive. However, please note that all of the data on the hard drive will be deleted during this process.

Related information



[Schedule Recording cannot be used.](#) on page 94

Recording List

Access recording list



In Live TV, press  /  /  button on your remote control and select **More > Recording List**.

Watch recorded programmes



In Live TV, press  /  /  button on your remote control and select **More > Recording List > Recorded**.

Select a recorded programme in the recording list and press  button to watch it.

Manage recording list



In Live TV, press  /  /  button on your remote control and select **More > Recording List > Recorded**.

• Delete recorded programme

Select a programme, press and hold  button on your remote control to start editing and press  button to delete it.



Enjoy Live TV

Manage schedule recording list

In Live TV, press //  button on your remote control and select **More > Recording List > Scheduled**.

You can adjust the schedule recording information or cancel scheduled recordings. Schedule recording items are identified with  icons.

- Delete scheduled recording

Select a scheduled recording, press and hold  button on your remote control to start editing and press  button to delete it.

- Edit scheduled recording

Select scheduled recording in the schedule list, then press  button to edit.











Note:

- The Recording List function may not be applicable in some models/countries/regions.

Reminder

Setup this feature to allow reminders to be displayed of future programmes.

Set up a reminder

1. In Live TV, press / button, or press //  button and select **Guide (EPG)** to display programme guide.
2. In Guide (EPG), press / button to select the channels. Press / button to select a programme that has not been aired.
3. Press  button to select **Reminder**.

Note:



- Reminder is only available for programmes that have not been aired yet.

Manage the reminder list

In Live TV, press //  button on your remote control and select **More > Recording List > Scheduled**.

You can change reminder information or cancel reminders. Reminder items are identified with  icons.

- Delete reminder

Select a reminder, press and hold  button on your remote control to start editing and press  button to delete it.

- Edit reminder











Select reminder in the schedule list, then press  button to edit.

Timeshift

This option allows you to pause and rewind Live TV. This function operates by recording temporarily to a storage device. Please ensure your storage device is connected and there is enough free disk space, otherwise Timeshift will not function.

Enjoy Live TV

There are several ways to use Timeshift.

- In Live TV, press  /  /  button and select **Timeshift**.
- In Live TV, press  /  /  /  button to display the info bar and choose .
- If your remote control has  button, press it and use D-pad to select  /  to launch Timeshift.

Learn about the timeshift control bar

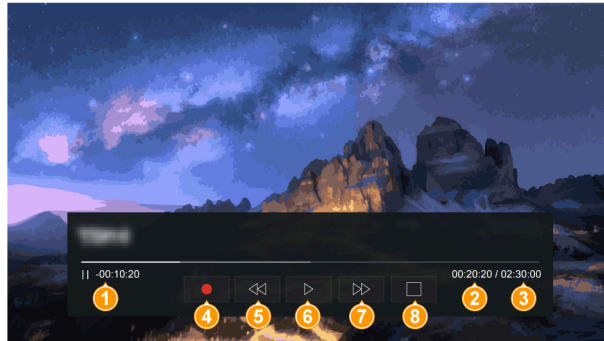

1 Unwatched time for buffered content

2 Current time

3 Total time

4 Record: to convert a Timeshift to a live recording of the current broadcast channel. Select , adjust recording settings and choose Save, then the programme content you have watched in Timeshift will also be saved to the storage device.

5 Fast backward: you can choose 2x, 4x, 8x or 16x.

6 Pause/Play



7 Fast forward: you can choose 2x, 4x, 8x or 16x.

8 Stop Timeshift: to exit the function and watch the current broadcast.

Note:

- The Timeshift function does not support analogue channels.
- The storage space of the device should be no less than 2GB. It is strongly recommended to use a USB mobile hard disk drive instead of a USB flash drive as the storage device.
- The Timeshift function may not be applicable in some models/countries/regions.

Timeshift related settings

Press  /  /  button on your remote control and select **All Settings > Channel > Recording & Time Shift**.

Enjoy Live TV

- **Setup**

When you connect more than one USB storage device to the TV, the one selected in **Setup** is initialised for launching Timeshift. When launching Timeshift, programme will be recorded temporarily to the selected storage device.

- **Permanent Timeshift**

When Permanent Timeshift is enabled, the TV will start Timeshift automatically every time you begin to watch a live TV channel. If you change the channel, Timeshift will restart from when the channel was changed. When Permanent Timeshift is turned off, Timeshift will begin from the time you start the function.

This function may not be applicable in some models/countries/regions.

- **Format Hard Disk**



Format the external USB disk to support Timeshift.

Related information

[Connecting USB Devices](#) on page 52

HbbTV

Access service from providers through HbbTV.

Press  button on your remote control, then select  **Settings > Channel > HbbTV**.







Enable or disable HbbTV functionality for all channels (only available for digital channels).

In Live TV, press  /  /  button to select **More > HbbTV**.



Enable or disable HbbTV functionality for the current channel (only available for digital channels).

When HbbTV service is enabled and the programme supports HbbTV, follow the instructions on the TV screen to select the corresponding button on the remote control to access the service.

Note:

- This function may not be applicable in some models/countries/regions.
- Some channels may not support the HbbTV service.
- HbbTV cannot be used during Timeshift or PVR.
- In some channels that support the HbbTV service, functions of  /  /  /  /  buttons in Live TV may be replaced by HbbTV service. You could try to press  button first or turn off HbbTV function, then try again.

CI+ Module Settings

Press  /  /  button on your remote control and select **All Settings > Channel > Advanced Settings > CI+ Module Settings**.

Review the CI+ settings: Common interface, CI card PIN and CAM Profile Search.

Note:

- You must obtain a CI+ module and card from the service provider of the channels you want to watch.
- Before you insert/remove the CI+ module, ensure that the TV is switched off. Then insert the CI card into the CI+ module in accordance with the Service Provider's instructions.
- Insert the CI+ module with the SmartCard in the direction marked on the module and SmartCard.

Enjoy Live TV

- Do not repeatedly insert or remove the Common Access Module as this may damage the interface and cause a malfunction.
- This function may not be applicable in some models/countries/regions.

Voice Service Setup



Set up voice assistant to control your TV by your voice.

Note:



- Voice Service feature may not be applicable in some models/countries/regions.
- To use this function, End User License Agreement and corresponding Smart feature privacy policy/terms and conditions may be required to be agreed to.
- The supported voice interaction languages and features may differ depending on the geographical area.
- Searched results may not provide complete results.
- The voice interaction rate differs with the volume/tone, pronunciation, and ambient sound environment (TV sound and ambient noise).
- Even if the TV is connected to the network, there may be no response due to Voice service server error.

Alexa Setup

Interact with Alexa by pressing and holding the microphone button on your remote control. You can ask Alexa to control this TV.

Before setting up the Amazon Alexa Service, connect your TV to the network and sign into your VIDAA Account at  >  **Account**. More information about how to sign into the VIDAA Account, please refer to [First-Time Use > User Account](#) in this manual.





How to set up Alexa

1. Press  button, select the  **Settings** icon, then select **System > Voice Service > Amazon Alexa**.
2. Select **Set voice assistant to Alexa** and **Set Up Alexa**. If you have selected Alexa during the first-time installation process, it will directly guide you to the **Set Up Alexa** steps.
3. For models with built-in microphone, you could choose whether to allow the use of built-in microphone. By using this function, you could enjoy Alexa voice service hands-free.
4. Select Amazon Alexa supported voice language from the selection.
5. You are now at the step 'Sign into your Amazon account'. Scan the QR code with your mobile device or visit the website on your mobile device or computer and enter the on-screen code. The code will expire after 10 minutes. If you do not have an Amazon account, please create one.
6. After you have linked the Amazon account, the TV screen will change to the next step. You can sign into your VIDAA account. If you have signed in before, this step will be skipped.
7. Now Alexa is set up and ready. You can enjoy interacting with Alexa using your voice by just pressing and holding the  button on your remote control. Ask Alexa after the tone.

Note:

- The Alexa function may not be applicable in some models/countries/regions.
- The setup steps above may vary. Please refer to the specific product.
- Shipment with voice remote control varies depending on TV models/countries/regions.
- You can use Alexa without signing into your account by skipping the sign in section. In this case, you can still use your voice to change the channel and control playback. Sign into your account in the settings menu at any time to enjoy more functions of Alexa.
- This feature requires Alexa built-in service. Otherwise, use external Alexa-enabled devices (e.g. Alexa App, Echo) to control your smart TV by using just your voice.

Benefits of Smart TV

- Download and install the remote control app on your mobile device at  >  **Settings** > **Connection** > **Mobile App Download**. Press the Microphone icon in the app to interact with Alexa on your TV.
- You can select the language used by Alexa at  >  **Settings** > **System** > **Voice Service** > **Amazon Alexa** > **Go to Alexa App** and select  > **Device options** > **Language**. This feature requires Alexa built-in service, which varies depending on TV models and countries/regions.

Related information

[Connect to a Wired \(Ethernet\) Network](#) on page 7

[Connect to a Wireless Network](#) on page 8

VIDAA Voice Setup



VIDAA Voice is a voice assistant to help you control the TV and search content, supporting several languages.

Before using VIDAA Voice, please check the following:

- Network connected.
- Voice remote paired. More information about how to pair the remote control, please refer to [Connecting to External Devices > Remote & Accessories > Connect Remote Control](#) in this manual.
- End User License Agreement and voice feature privacy policy/terms agreed.



How to set up VIDAA Voice

To access the Voice Service centre and set voice assistant to VIDAA Voice, you can choose one of the following options:

- Just press  button on your remote control.
- Press  button to select  **Settings** icon and select **System** > **Voice Service**.

When VIDAA Voice is selected as your voice assistant, select the language of VIDAA Voice in Voice Service centre.

How to interact with VIDAA Voice

- You can press and hold the  button on your remote control, say a command, and then release the button.
- For remote control without the Microphone button, download and install the app on your mobile device at  >  **Settings** > **Connection** > **Mobile App Download**. Press the Microphone icon in the app to interact with VIDAA Voice.

Note:

- VIDAA Voice may not be applicable in some models/countries/regions.
- VIDAA Voice only supports some languages.
- Shipment with remote control varies depending on TV models/countries/regions.
- The existing functional specifications may be changed if VIDAA Voice is updated.

Related information

[Connect to a Wired \(Ethernet\) Network](#) on page 7

[Connect to a Wireless Network](#) on page 8



[Using the Mobile App](#) on page 40

[Connect Remote Control](#) on page 42



Benefits of Smart TV

Google Smart Home Service Setup

For specific models and countries/regions, Google Smart Home Service function is available. Set up Google Smart Home Service to control your smart TV with Google Home devices or the App. You can change channels or inputs, adjust volume and more.

Before setting up the Google Smart Home Service, connect your TV to the network and sign into your VIDAA Account at  >  **Account**. More information about how to sign into the VIDAA Account, please refer to [First-Time Use > User Account](#) in this manual.

STEP 1: Set up Google Smart Home Service on TV

1. Press  button on your remote control to select  **Settings** icon and select **System > Voice Service > Google Smart Home**. Select **Set up now**.
2. Sign into your VIDAA account. If you have signed in before, this step will be skipped.
3. Give your TV a name.

STEP 2: Set up in Google Home app

Follow the setup instructions on-screen to set up the Google Smart Home Service.

1. Download and install the Google Home app on your mobile device, then open the app.
2. Find and select VIDAA Voice service in the app.
3. Follow the instructions in the app to link your VIDAA account signed in on your TV to your Google Account.

Google Smart Home Service is set up and ready. Control your smart TV by using your voice through the Google Home device or App.

Note:

- Google Smart Home Service may not be applicable in some models/countries/regions.
- The setup steps above may vary. Please refer to the actual product.



Related information

[Connect to a Wired \(Ethernet\) Network](#) on page 7



[Connect to a Wireless Network](#) on page 8

Yandex Smart Home Service Setup

Yandex Alice voice assistant can obey certain commands to help you change the TV's configuration.

Before setting up Yandex Smart Home Service, connect your TV to the network and sign into your VIDAA Account at  >  **VIDAA Account**. More information about how to sign into the VIDAA Account, please refer to [First-Time Use > User Account](#) in this manual.

STEP 1: Set up Yandex on TV

1. Press  button on your remote control to select  **Settings** icon, then select **System > Voice Service > Yandex**. Select **Set up now**.
2. Sign into your VIDAA account. If you have signed in before, this step will be skipped.
3. Give your TV a name.

STEP 2: Set up in Yandex App

Follow the instructions on the TV to enable Yandex Smart Home Service.

Benefits of Smart TV

1. Download the Yandex app on your mobile device.
2. Open the app and sign into your Yandex account.
3. In the Yandex app, go to "Devices" > "Smart Home", click add device icon and select "VIDAA Voice".
4. Merge Account by signing in to your VIDAA Account.

Yandex Smart Home Service is set up and ready. Now you can control your Smart TV with Yandex Alice devices or the Yandex app to change channel, change inputs, adjust volume and more, just by asking Alice.

Note:

- The Yandex function may not be applicable in some models/countries/regions.
- The setup steps above may vary. Please refer to the specific product.

Related information

[Connect to a Wired \(Ethernet\) Network](#) on page 7

[Connect to a Wireless Network](#) on page 8

Using Apps

Press  button on your remote control and select the app you want.



Factory pre-installed apps are available to choose according to your entertainment preference.

Install an App

Even though your TV has factory pre-installed apps, there may be others that you would like to download.

Install an app from the app store

To install an app:

1. Press  button on your remote control and select **app store**.
2. Use the navigation buttons on your remote control to select the app that you want to install, press  button to enter the detail page.
3. Select **Install**. The selected app will be installed on the TV.

Alternatively, you can search for an app directly and press  button to enter the detail page to install it.

Note:

- To use this function, your TV must be connected to the Internet.
- Under certain circumstances, you may need to sign into your VIDAA account first before installing the app.
- Adding apps is free, but it might cost you money when using some apps.
- Some app services are provided by third-party service providers, for more information about these apps, please refer to the instruction menu of the service provider.

Related information

[Connect to a Wired \(Ethernet\) Network](#) on page 7



[Connect to a Wireless Network](#) on page 8

Benefits of Smart TV

Search Apps

Search apps

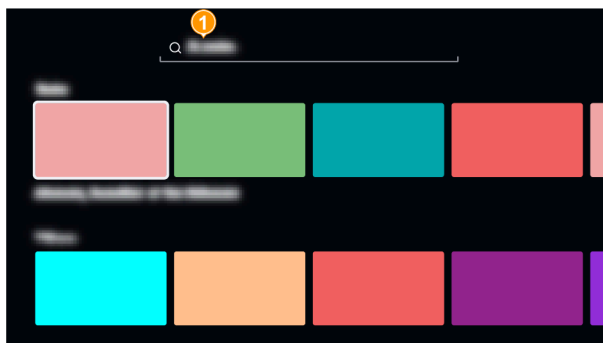

- **Search from the Home page**

Press  button on your remote control to enter the Home screen, use the navigation buttons to move the focus to the  Search icon on the left side of the screen, press  button to enter and search for the apps you are looking for.



-  **Type keywords**

- **Search from the app store**







Press  button on your remote control to display the Home screen and then select the app store. You will find the  Search icon on the top right corner.

- **Voice search**

If your remote control supports voice function, press and hold  button and use your voice to search for the app you are looking for.

If your TV supports the hands-free wake-up function, you could also search the app with your voice directly. Just say "Alexa" or "Hey VIDAA" to call up the voice assistant.

Remote control quick access

- There will be app buttons on your remote control, you can open the app directly by pressing the app button without going to the Home screen.
- If your remote control has  /  /  button, you can customise the button to launch an app which only appears on the Home screen, directly from the remote control.
 1. Press and hold the  /  /  button on the remote control.
 2. Select an app you desire.
 3. Choose **Save** to confirm the operation.

Note:

- Availability of content and applications varies by countries/regions.
- Remote control varies by countries/regions.

Related information

[Benefits of Smart TV > Voice Service Setup](#) on page 29

Benefits of Smart TV

Manage Apps

Move apps

1. On the home screen, select the app you want to move, then press and hold the **OK** button to manage it.
2. Press **←/→** button to move the app.
3. Press **OK** button to save the position.

Remove an App

Remove an app from the Home screen

1. On the home screen, select the app you want to remove, then press and hold the **OK** button to manage it.
2. Press **V** button and then select **Remove**.
3. The app you selected will be removed from the Home screen, but you can still find it in the app store and install it again.

Note:

- Some apps cannot be removed.

Uninstall an app from app store

1. Open the app store, select the app you want to uninstall and press **OK** button to enter.
2. Select **Uninstall**.
3. The app you have selected will be uninstalled, but you could still install it again from the app store.

Note:

- Some apps cannot be uninstalled.

VIDAA Kids

Before you start

- You need a VIDAA Account to create a kid's profile.
- VIDAA Kids is available in select countries/regions.

Create a VIDAA Kids profile

Create a VIDAA Kids profile to customise a kid-friendly environment and ensure a safe, personalized experience for your children.

There are two ways to create a VIDAA Kids profile.

- **Using your VIDAA account:** Press **Home** button on your remote control and select **Account** icon in the navigation bar. After signing into your VIDAA account, select **Add a Kid Profile** and follow the on-screen instructions to finish the setup process.
- **Using the VIDAA kids application:** Open the **VIDAA Kids** application, select the user icon on the side navigation bar of the VIDAA Kids home page and follow the on-screen instructions to complete the setup.









Note:

Benefits of Smart TV

- To create a VIDAA Kids profile, you must create or enter a Parental Control PIN. This PIN is the same as the Parental Control PIN in  **Settings > System**.
- Once a kid's profile is created, the Parental Control PIN is essential for managing the profile. You must enter it when switching profiles, exiting the VIDAA Kids app, or accessing kids' settings. Note that only limited buttons on your remote control are available while a kid's profile is in use.
- With a kid profile in VIDAA kids, VIDAA Voice can only search for kid-friendly content. Alexa is disabled in kids' mode.

Enter VIDAA Kids

There are several ways to enter VIDAA Kids. If you have not created a VIDAA Kids profile, you can only use limited functions in guest mode.

- **Using the navigation bar:** Press  button on your remote control. Then, go to the navigation bar on the side of screen and select the  kids icon.
- **Using the application row:** Press  button on your remote control and select **VIDAA Kids** in the application row.
- **Using your VIDAA account:** Sign into your VIDAA account, press  button on your remote control and choose  Account. On the **Who's watching?** screen, select the VIDAA Kids profile you previously set up.
- **Using the remote control:** If your remote control has the **KID** button, press it to enter **VIDAA Kids** directly. If your remote control does not have the **KID** button but does have  /  /  button, you can customise this button to launch **VIDAA Kids** directly from the remote control.

Note:

- VIDAA kids is only available in select countries/regions. If it's not available in your area, it will open other content instead.
- The function and name of the KID button may vary depending on the model, country, or region.

Exit VIDAA Kids

On the home page of **VIDAA Kids**, press the  /  button, a dialogue will appear asking you to confirm that you want to exit **VIDAA Kids**.

If you have set a VIDAA Kids profile, select **Exit**. You will need to enter the Parental Control PIN to exit. If you have not set a VIDAA Kids profile, you will exit **VIDAA Kids** directly.

Kids Settings

To access **Kids Settings**, select the Kids Settings option in the side navigation bar on the **VIDAA Kids** home screen. You will need to enter the Parental Control PIN to make any changes.

Note:

You must have a kid's profile set up to access **Kids Settings**.

Benefits of Smart TV

• Manage Kid Profile

- **Manage Age Group:** Select age groups for the streaming content on the kid's home screen. This selection will NOT affect the TV channels in **Manage Channels**.
- **Manage Channels*:** TV channels are viewable and managed by each kid's profile. *This function may not be available in your country or region. The content will be affected by the content block value you selected in the Parental Control from the TV settings.
- **Manage Time Limits:** Set limits on your kids' viewing activities, including connected TV devices(e.g., game consoles) if applicable(see Manage Device). You can set Screen Time and Bedtime. If enabled, **Viewing Restrictions** will automatically turn on.
- **Theme:** Customise the background for the kid's home screen.
- **Manage Device:** Make externally connected devices available on the kids' home screen for the selected kid profile. Make sure the external device is powered on, then select the Save option.

• Viewing Restrictions

If enabled, the **Who's watching** screen will always appear, and you must select a profile after powering on the TV.

• Manage Parental Control PIN

A Parental Control PIN is a four-digit numerical code that a parent or guardian can set to prevent kids from accidentally viewing inappropriate content on VIDAA Kids and the TV(including channels, apps, etc.). You can use **the same PIN** for both VIDAA Kids' Settings and the TV settings( **Settings > System > Parental Control**). If you set up content block on the TV, it will also apply to VIDAA Kids. However, the available functions are different in VIDAA Kids and the TV. Please be sure to configure settings in both sections as needed.

• Max Volume Limit

Set a maximum volume limit to protect your kid's hearing. The maximum volume limit is 30.

• Eye Care Mode

When enabled, this mode uses low blue light to reduce eye strain. The setting is related to the **Low Blue Light** option found in  **Settings > Picture > Picture Mode Settings > Advanced Settings > Colour**.

• More options on VIDAA Mobile App

Remotely set time limits and monitor your kids' viewing behaviour.



Using the VIDAA ART

Numerous artworks or photos are presented for you to browse or set as a screensaver.

Note:

- Functions in VIDAA ART will be different according to different models.
- We recommended you to login the VIDAA Account to enjoy the high-quality pictures and art pieces.





Enter the VIDAA ART

- Press  button on your remote control to enter the Home screen, select the **VIDAA ART** in the app row and press  button to enter.
- Under home page or input sources without signal, when there is no operation on your device for more than 5mins, TV will enter art mode automatically. You can also set the time in **Vidaa Art setting**.

Other Entrances for Canvas TV

Benefits of Smart TV

There are other 2 entrances besides the methods above for Canvas TV.

- 1. You can press  button on your remote control to enter the Home screen, use the navigation buttons to move the focus to the  art icon on the left side of the screen, press  button to enter.
- 2. Press  button while using the TV, TV will switch to art mode.



Note:

For Canvas TV, to turn it off completely, press and hold the  button on the remote control.

Art display

Use the navigation buttons to select an artwork and press  button to display it in full screen mode. You can also see the art display when the TV enters art mode.

Press  or  button to switch between different pictures.

Press  or  button to show the art display options as the following items.

- **Frame Selection**

Select the preset frame to enhance the artistic effects.

- **Background Colour**

For images that do not cover the full screen, users can choose different background colours.

- **Display options**

Choose from In Order or Shuffle.

- **Rotation**

You can choose the rotation time for your artwork according to your preference.

This function will be applicable after signing in your VIDAA account and have the benefits or subscription.

This function may not be applicable in some models.

- **Brightness**

Adjust the brightness of the screen.



This function is only applicable in art mode.

- **Contrast**

Adjust the contrast level to increase or decrease how bright images appear.

This function is only applicable in art mode.

Add artworks to favourite playlist

1. In VIDAA ART, select the content you want to see and press  button to show it in full screen,
2. Press  button again to show the detail page.
3. Select **Add to favourite**.

You can also select the content you like, press and hold  button to add it to favourite directly.



Note:



- You need to sign into VIDAA account first if you want to add favourite.

Benefits of Smart TV

- Some artworks do not have the detail page and cannot be added to favourite, like the artworks in My photo, Video art. Only artworks delivered from the cloud have detail page and can be added to favourite list.
- Some artworks can only be added to favourite list after you getting the art benefit.

VIDAA Art Settings

At the home page of VIDAA ART, use the navigation buttons to select  settings icon, press  button to enter.

Alternatively, press  button to enter home screen and select  **Settings > System > Advanced Settings > VIDAA Art setting.**

- **Show Art after**

Set up the time to go to the art mode automatically when the TV is idle.

- **Art Source**

Set up the art mode screen source.

You need to sign into VIDAA account first if you want to use art source.

- **Sleep After**

Set up the time to power off TV under art mode.

- **Motion Detector**

By using motion detector, the artwork will be displayed based on the surrounding motion situation.

This function is only available in Canvas TV.

- **Night mode**

After turning on this function, the screen will not automatically light up when someone passes by at night.

This function is only available in Canvas TV.

Note:

- This function may not be applicable in some models.
- The options will vary depending on different models/countries/regions.

Precautions for Canvas TV

- Do not display still images on the screen for long periods of time.
- Do not block the motion sensor of the TV, otherwise the motion sensor and the brightness can be affected.
- The sensor's effectiveness can fluctuate based on the setup and surroundings of the TV.
 - In a context where non-standard light sources are employed alongside the regular ones, the sensor's motion detection capabilities could be altered by the placement, variety, and quantity of such light sources.
 - If the TV is installed at an improper height, either too high or too low, it may result in the sensor's suboptimal performance.
 - If the surroundings of the TV are excessively dim or glaring, it might lead to a reduction in screen brightness or hinder the sensor's optimal operation.
 - The motion sensor could be triggered by the movement detected from a blinking LED light, an animal's motion, a vehicle passing by outside the window, or any other similar event, prompting it to activate.

Benefits of Smart TV

Using the Browser to Search the Internet

Press  button on your remote control and select **Browser**.

You can enter websites and browse information on the Internet.

Make sure your TV is connected to the network before accessing the internet via the Browser.

You could also press and hold  button to go one page up or down.

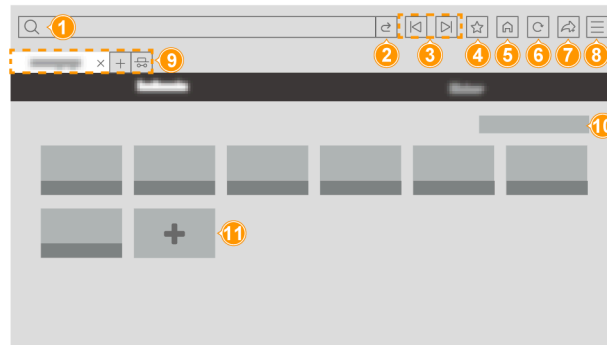

- 1 Enter website you want to visit
- 2 Visit/Search
- 3 Back/Forward: switch among webpages
- 4 Add the website you are viewing to Bookmarks
- 5 Back to the Homepage
- 6 Reload/Stop the website
- 7 Add the website to Shortcuts on the Home screen
- 8 Enter the Menu
- 9 Add/remove webpages, or add private webpages
- 10 Manage websites in Bookmarks
- 11 Add websites to Bookmarks

Note:

- The image is only for reference and may differ from the actual product.
- Some contents in the Browser may not be played properly.

Related information

[Data Protection and Security](#) on page 68

[Connect to a Wired \(Ethernet\) Network](#) on page 7

[Connect to a Wireless Network](#) on page 8





Benefits of Smart TV

Using the Mobile App

Press  button on your remote control and select  **Settings > Connection > Mobile App Download**.

Scan the Mobile App download QR code on screen to install the app on your mobile device. It is a convenient and easy way to control your TV. This app is available on both Android and iOS.

To connect to your TV after installing the mobile app:

1. Agree with end user license, disclaimer and privacy policies on the TV. If you are not sure whether you have agreed, check by pressing  button on your remote control and select  **Settings > Support > Disclaimer and Privacy > Data Sharing, Privacy and EULA**.
2. Make sure your mobile device and TV are connected to the same network environment.
3. To use this function, switch on **Content Sharing** by pressing  button on your remote control and select  **Settings > Connection > Mobile Device Connection > Content Sharing**.
4. Open the mobile app and select the TV device you want to connect to.

What you can do with the app:

- Turn the TV on or off
- Volume up or down
- Switch channels
- Input characters with your mobile device keyboard
- Share pictures, music, or videos from your mobile device to the TV

Related information

[Connect to a Wired \(Ethernet\) Network](#) on page 7

[Connect to a Wireless Network](#) on page 8

Use Energy Saving Functions

Use energy saving functions to reduce the TV power consumption.

Use Timer Settings

Use the following timer setting functions to reduce the TV power consumption.

• **Sleep Timer**

Press  button on your remote control and select  **Settings > System > Timer Settings > Sleep Timer**.

Set the sleep timer to automatically turn the TV off at the specified time.

• **Power Off Timer**

Press  button on your remote control and select  **Settings > System > Timer Settings > Power Off Timer**.

Set the time you want the TV to turn off automatically.

Benefits of Smart TV

- **Auto Sleep**

Press  button on your remote control and select  **Settings > System > Timer Settings > Auto Sleep**.

Set the amount of time that you would like the TV to auto power off after a period of no activity.

This function may not be applicable in some models/countries/regions.

- **Auto Standby with No Signal**

Press  button on your remote control and select  **Settings > System > Timer Settings > Auto Standby with No Signal**.

When you select this option, the TV will go to standby if there is no signal after the set time.

This function may not be applicable in some models/countries/regions.

Adjust Brightness of the Picture

- **Automatic Light Sensor**

Press  button on your remote control and select  **Settings > Picture > Picture Mode Settings > Advanced Settings > Brightness > Light Sensor Settings**, and turn on **Automatic Light Sensor**.

When **Automatic Light Sensor** is **On**, the TV can automatically decrease the brightness value if the ambient light is dark, this can reduce the TV power consumption.

- **Dynamic Backlight Control**

Press  button on your remote control and select  **Settings > Picture > Picture Mode Settings > Advanced Settings > Brightness > Dynamic Backlight Control**

Note:

- Options may not be applicable depending on your model/country/region and the picture mode you selected.

Use Solar Powered Remote

Use Solar Powered Remote to reduce power consumption. You can charge the remote by exposing the solar panel to light.

Note:

- Solar Powered Remote may not be applicable in some models/countries/regions.

Play Audio Only

Select your desired input, then press  /  /  button on your remote control, select **Audio Only**.

When this option is selected, the screen will not display the picture, only audio can be heard. This can lower the TV power consumption.

Note:

- This function may not be applicable in some input sources.

Connecting to External Devices

Connection Guide

Remote & Accessories

- [Connect Remote Control](#)
- [Use HDMI & CEC](#)
- [Control the TV with a Keyboard, Mouse or Gamepad](#)

Connecting Bluetooth Devices

- [Turn on Bluetooth Feature on your TV](#)
- [Connect a Bluetooth Device](#)
- [Listen to the Audio through Bluetooth Devices](#)
- [Listen to your Mobile Device Audio through the TV Speaker](#)

Displaying screen or content of external device on the TV

- [Screen Sharing](#)
- [Content Sharing](#)
- [AirPlay and HomeKit](#)

Connecting Input Devices

- [Set Top Box](#)
- [Blu-ray or DVD Player](#)
- [USB Devices](#)
- [Audio Visual\(AV\) Devices](#)
- [PC](#)

Connecting Output Devices

- [Headphones](#)
- [Speakers or other Audio Receivers](#)
- [Digital Audio System with ARC/eARC](#)

Remote & Accessories

Connect remote controls or other accessories, such as keyboards, mouse and gamepad devices, to interact with your Smart TV with ease.

Connect Remote Control







Connect a Bluetooth remote control

Pair the Bluetooth remote control with the TV after you power the TV on.

Keep the remote control within 3 metres from the TV. Press any button (except power and mic button) to pair.

Note:

Connecting to External Devices

- You can choose to close the remote control auto pairing function by pressing  button on your remote control and select  **Settings > Connection > Bluetooth > Remote Control Auto Pairing** to turn it off.
- In special cases, press and hold  /  /  button to pair.
- Before pairing, check to ensure the Bluetooth function is turned on by pressing  button on your remote control and select  **Settings > Connection > Bluetooth**.
- This function may not be applicable in some models/countries/regions.
- If an error occurred while trying to pair the remote control, it could have been caused by interference. Try to remove what is causing the interference and try pairing again.
- If an error occurred with the remote control while using sufficiently charged batteries, you can remove the batteries for 1~2 seconds then insert them once again. Now the remote control should work correctly.
- The remote control cannot be paired with the TV while the TV is in standby mode.

Use HDMI & CEC

Use the TV remote to control external devices that are connected to the TV by a HDMI cable. The external devices need to support HDMI & CEC function.

Press  button on your remote control and select  **Settings > Connection > HDMI & CEC**.

Connect an external device through HDMI & CEC function

Press  button on your remote control and select  **Settings > Connection > HDMI & CEC > CEC Control**.

Allow HDMI devices to control each other.

1. Set **CEC Control** to **On**.
2. Connect a HDMI & CEC compatible device to the TV.
3. Turn on the connected external device. The device will be connected to the TV automatically. After connection is completed, you can access the menu of the connected device on your TV screen using your TV remote to control the device.
4. When CEC control is enabled and HDMI & CEC compatible external devices are turned off, the TV will enter the standby mode. The function needs to be supported by the external device.

Enable device auto power off

Press  button on your remote control and select  **Settings > Connection > HDMI & CEC > Device Auto Power Off**.

Set to **On** to turn off HDMI & CEC compatible external devices when the TV is turned off.

Enable device auto power on

Press  button on your remote control and select  **Settings > Connection > HDMI & CEC > Device Auto Power On**.

Set to **On** to turn on HDMI & CEC compatible external devices when the TV is turned on.

This feature is applicable when TV input source is pre-set to the corresponding external device.





Connecting to External Devices

Enable TV auto power on

Press  button on your remote control and select  **Settings** > **Connection** > **HDMI & CEC** > **TV Auto Power On**.

Set to **On** to turn on the TV when HDMI & CEC compatible external devices are turned on.

HDMI Format function

Under HDMI source, press  /  /  button on your remote to enter quick menu and select **HDMI Format**. You could also press  button on your remote control and select  **Settings** > **Connection** > **HDMI & CEC** > **HDMI Format**.

Please select **Enhanced Format** if your HDMI device supports 4K HDR. If it does not support 4K HDR, please select **Standard Format**. If you are not sure, please select **Auto**.

Note:

- This function may not be applicable in some models/countries/regions.
- The options above will vary depending on the model variant used.
- HDMI cables must be used to connect HDMI & CEC compatible devices to your TV.
- The HDMI & CEC feature of the connected device must be turned on.
- If you connect a HDMI device that is not HDMI & CEC compatible, the HDMI & CEC control features will not work.
- If the connected HDMI device does not support HDMI & CEC control, the feature will not work.
- The HDMI & CEC feature supports One Touch Play, Routing Control, System Standby, Device OSD Name Transfer, Remote Control Pass Through, Give Device Power Status, System Audio Control.

Related information

[HDMI & CEC Issues](#) on page 105

Control the TV with a Keyboard, Mouse or Gamepad

Connect a keyboard, mouse or gamepad to control your TV with ease.

How to connect a keyboard, mouse or gamepad

Connect a USB keyboard, mouse or gamepad



Plug the keyboard, mouse or gamepad cable into the USB port of your TV.



Connect a Bluetooth keyboard, mouse or gamepad

1. Press  button on your remote control, select  **Settings** > **Connection** > **Bluetooth** and set **Bluetooth** to **On**.

Connecting to External Devices

2. Before pairing your Bluetooth device, make sure it is in the pairing mode and placed within pairing range. To put your Bluetooth device in pairing mode, refer to the user manual of your device.
3. Locate the Bluetooth device by pressing  button on your remote control and select  **Settings > Connection > Bluetooth > Bluetooth Device**.

Note:

- Keyboard, mouse, or gamepad connected via USB or Bluetooth technology may not be usable with some Apps.
- If your device was not detected, position it closer to the TV or move away obstacles between them and try again.
- Bluetooth function may not be supported depending on the models/countries/regions.
- A maximum of four Bluetooth gamepads can be connected to the TV. If the TV has connected to a relatively high power Bluetooth device, or the gamepad is of high power Bluetooth, up to two gamepads can be connected.

Using the Gamepad

Supported gamepad models









- PlayStation Dualsense controller
- PlayStation DualShock 4 V2 controller
- Xbox One S controller
- Xbox Elite controller
- Xbox Series X/S controller
- Luna controller
- MOGA XP5-X Plus Bluetooth controller

Using the Gamepad as a Controller



- ① Left directional pad
- ② Right directional pad
- ③ Left joystick
- ④ Quick panel
- ⑤ Touch pad

Connecting to External Devices

Button	Description
Left joystick or left directional pad	Up/down/left/right navigation buttons
 button or  button	Confirmation button
 button or  button	Return or cancel button
Quick panel	Press and hold to display the Home screen
 button or  button	Enter settings
 button or  button	Exit the menu or exit the application
Right directional button	<ul style="list-style-type: none"> Up/Down: Volume up/down; Channel up/down (only in Live TV) Press to mute
Press and hold left and right directional pads at the same time	Power off/Power on
Touch pad (if controller has a touchpad)	Available when using the Browser

Note:

- The image of gamepads above may vary. Please refer to the actual product.
- Some keys may not be available depending on gamepad models.
- The operation may differ depending on inputs, apps or cloud games.

Entering letters, numbers and special symbols by using voice

Use the remote control's microphone and virtual keyboard to enter text on your TV.

Before using the function, please check the following:

- Network connected.
- Voice remote paired. More information about how to pair the remote control, please refer to [Connecting to External Devices > Remote & Accessories > Connect Remote Control](#) in this manual.
- End User License Agreement and voice feature privacy policy/terms agreed.
- VIDAA Voice and language English are selected in the Voice Service centre.

When the focus is on the text input field, press  button on the remote control to call up the virtual keyboard with microphone prompts.

Press and hold the  button on your remote control, speak to the microphone on the remote control, and then release the button. What you say appears on the screen as text.

Note:

- The remote control with  button is only available in some models/countries/regions.
- Entering text with your voice may not be supported for some functions.
- This function may not be applicable in some models/countries/regions.

Connecting to External Devices

- Please say letters, numbers or symbols and wait for the device to respond, otherwise what you say may not be recognised.

Related information

[Connect to a Wired \(Ethernet\) Network](#) on page 7



[Connect to a Wireless Network](#) on page 8

[Connect Remote Control](#) on page 42

[VIDAA Voice Setup](#) on page 30

Connecting Bluetooth Devices

You can connect to devices using Bluetooth technology.

Press  button on your remote control and select  **Settings > Connection > Bluetooth**.

Note:

- Bluetooth function may not be applicable in some models/countries/regions.

Turn on Bluetooth Feature on your TV





Press  button on your remote control and select  **Settings > Connection > Bluetooth** and set **Bluetooth** to **On**.

Note:

- This function may not be applicable in some models/countries/regions.

Connect a Bluetooth Device

To pair a Bluetooth device, such as Bluetooth headphones, speakers, keyboards, mouse or even mobile devices:

1. Press  button on your remote control, select  **Settings > Connection > Bluetooth** and set **Bluetooth** to **On**.
2. Before pairing your Bluetooth device, make sure it is in the pairing mode and placed within pairing range. To put your Bluetooth device in pairing mode, refer to the user manual of your device.
3. Find the Bluetooth device name by pressing  button on your remote control and selecting  **Settings > Connection > Bluetooth > Bluetooth Device** and select it. The device will be automatically connected to the TV.

Note:

- Only one Bluetooth speaker or Bluetooth headphone can be connected to the TV. If a new Bluetooth speaker or headphone connects to the TV, the existing one will be disconnected automatically.
- Some compatibility issues may occur depending on the Bluetooth device support.
- Bluetooth keyboards may not be functional with some applications.
- The TV and Bluetooth devices may become disconnected if the distance between them is too long.
- This function may not be applicable in some models/countries/regions.

Listen to the Audio through Bluetooth Devices

Pair the Bluetooth audio device using the TV Bluetooth setup process. Refer to the user manual of your audio device, such as Bluetooth speaker or sound bar, for detailed instruction.

Connecting to External Devices

After the Bluetooth connection is completed, press  button on your remote control, select  **Settings** > **Sound** > **Audio Output** > **Bluetooth Speaker** to listen to the audio through Bluetooth devices.

Note:

- Compatibility issues may occur depending on the Bluetooth device.
- Sound quality may be affected by any obstacles between the Bluetooth audio device and the TV, or other connection issues.
- If the Bluetooth audio device fails to connect, check the Bluetooth status of the device is working correctly.
- The TV and Bluetooth device may become disconnected if the distance between them is too far.
- This function may not be applicable in some models/countries/regions.



Listen to your Mobile Device Audio through the TV Speaker

Press  button on your remote control, select  **Settings** > **Connection** > **Bluetooth** > **Music Sharing**.

Play sound of smart device through the TV's built-in speakers via Bluetooth.

1. Turn on the Bluetooth of your smart device and select your TV from its Bluetooth device list.
2. Select the media content to play on your smart device and the audio will be played through the TV speaker.

Note:

- To use this function, make sure to select **TV Speaker** at  >  **Settings** > **Sound** > **Audio Output**.
- This function may not be applicable in some models/countries/regions.



Related information

[Select Speakers](#) on page 63

Screen Sharing

You can mirror the screen of your mobile device (Android) or PC (Windows 10 and above) on the TV.











1. Set your TV to the wireless network connection.
2. Press the  /  button on your remote control and select **Screen Sharing** on your TV.
3. Turn on the WLAN network of your device.
4. Turn on the casting function of your device. The setting name, icon and location may vary depending on the device. The feature may be called "Wireless display", "Smart View", "Wireless projection", etc.

Connecting to External Devices

- Find the TV name in the searching list of your device and select it. Wait for the connection progress to complete and the screen of your device will be mirrored on the TV.

Note:



- Some devices may not support casting. To check whether your device supports casting, refer to the device's user manual.
- Press  button on your remote control, select  **Settings** > **Connection** > **Mobile Device Connection** > **Screen Sharing** and switch it on. Then, you can share your device's screen directly without opening the **Screen Sharing** in **Input** on your TV. (We do not recommend to turn on the switch as it may influence the using experience when using Screen Sharing.)
- Screen Sharing menu may not be available in  **Settings** > **Connection** > **Mobile Device Connection** depending on models.
- To turn off **Screen Sharing**, disconnect the external device or press  or  button on the remote control.
- When playing video or audio, press  /  /  button on your remote control and select **Audio Only** to turn off the screen while the video or audio continues.
- If you are using an Apple device, refer to [Connecting to External Devices > Using AirPlay and HomeKit](#) in this manual.

Content Sharing

Content Sharing allows you to view media content, like videos, music or photos saved in your mobile (Android) or PC (Windows 10 and above) device on your TV screen. You can also share videos from streaming apps on mobile device to the TV.







Share Media Content from your Device

- Connect your TV and device to the same network.
- Turn on **Content Sharing** by pressing  button on your remote control, select  **Settings** > **Connection** > **Mobile Device Connection** > **Content Sharing**.
- Choose a media content on your device and select cast setting or icon. The procedure, setting name, icon and location may vary depending on the device. Please refer to the mobile device or PC's user manual for specific settings steps.
- Find the TV name in the searching list of your device and select it.





Connecting to External Devices

5. Agree in TV request pop-up window, and wait for the connection progress to complete. When you connect a device for the first time, a pop-up will appear:
 - **Always Agree:** Select **Always Agree** to set your device as a trusted device, and there will no pop-up from the second time.
 - **Agree:** Select **Agree** and TV will play the content sharing from the device.
 - **Disagree:** Select **Disagree** and TV will not play the content sharing from the device.

Play Media Content Stored in External Device on TV

1. Connect your TV and device to the same network.
2. Turn on **Content Sharing** by pressing  button on your remote control, and selecting  **Settings** > **Connection** > **Mobile Device Connection** > **Content Sharing**.
3. Make sure your media content stored in your device are visible through the local network. The procedure depends on devices. Please refer to the mobile device or PC's user manual for specific settings steps.
4. Select connected device on the TV.
 - Method 1: Press  /  button on your remote control, and select **Content Sharing (device name)**.
 - Method 2: Press  button on your remote control, and select **Media** > **Content Sharing (device name)**.
5. Select a media content item from the list to play.

Note:

- Some devices may not support content sharing function.
- If your device does not support content sharing, you can download an app that supports the function to connect to your TV. For more information, please refer to [Benefits of Smart TV > Using the Mobile App](#) in this manual.
- To turn off Content Sharing, disconnect the external device or press  /  button on the remote control.
- When playing video or audio, press  /  /  button on your remote control and select **Audio Only** to turn off the screen while the video or audio continues.
- Content may not be played depending on the file format.
- Content may not be played smoothly, or the function may not work properly due to the network condition. It is recommended that you connect the device to a 5 GHz router.
- If you are using an Apple device, refer to [Connecting to External Devices > Using AirPlay and HomeKit](#) in this manual.

Related information

[Connect to a Wireless Network](#) on page 8







Using AirPlay and HomeKit

Using AirPlay

Use AirPlay to share audio and video content wirelessly from your iPhone, iPad, or Mac to your TV. Stream music and videos, share your photos, or mirror exactly what is on your device screen.



1. Make sure your Apple device is connected to the same network as your TV.

Connecting to External Devices





- Turn on AirPlay on your TV.
 - Press  button on your remote control, and select  **Settings > Connection > AirPlay and HomeKit > AirPlay and HomeKit Settings**, set **AirPlay to On**.
 - Press  /  button on your remote control and select **AirPlay**, enter **AirPlay and HomeKit Settings** and set **AirPlay to On**.
- Locate the AirPlay icon on supported media apps, or the Screen Mirroring icon in Control Centre on your Apple device. Depending on the content, these steps may vary.
 - To mirror your device screen, open Control Centre and tap Screen Mirroring .
 - To stream audio from supported music or podcast apps, tap AirPlay audio .
 - To stream video from supported apps, tap AirPlay video .
- Select your TV from the list to begin using AirPlay.

Using HomeKit

Use HomeKit to control your TV easily and securely with your Apple devices.

- Press  button on your remote control, and select  **Settings > Connection > AirPlay and HomeKit > AirPlay and HomeKit Settings**, locate the HomeKit section and select **Set Up**.
- The HomeKit setup screen will display a pairing QR code on the TV. Use your iPhone or iPad to scan the QR code, then follow the on-screen directions to complete HomeKit setup.

Note:

- To use AirPlay, your TV must support AirPlay.
- AirPlay and HomeKit may not be applicable in some models/countries/regions.
- The icons are only for reference. In some apps, you may have to tap another icon first.
- If an AirPlay passcode appears on your TV screen, enter the passcode on your Apple device to continue.
- To turn off AirPlay, disconnect the external device or press  /  button on the remote control.
- When playing video or audio, press  /  /  button on your remote control and select **Audio Only** to turn off the screen while the video or audio continues.
- Available operations vary depending on the version of the app and software.
- Use of the Works with Apple badge means that an accessory has been designed to work specifically with the technology identified in the badge and has been certified by the developer to meet Apple performance standards. Apple is not responsible for the operation of this device or its compliance with safety and regulatory standards.

Related information





[Connect to a Wireless Network](#) on page 8

Connecting a Set Top Box

Before connecting a Set Top Box to the TV, make sure the TV and Set Top Box are switched off.

Most STB's can be connected via HDMI, HDMI offers the best picture and sound quality. For more information about how to connect a Set Top Box to your TV, please refer to [Connecting to External Devices > Connecting Audio Visual \(AV\) Devices](#) in this manual.





Connecting to External Devices

When the connection is completed, turn on your TV and Set Top Box, switch to the input source by pressing the  button, then select the  **Input** icon on Home screen or press the  /  button to change to the port that you connected your Set Top Box to.

Connecting a Blu-ray or DVD Player

Before connecting a Blu-ray or DVD player to the TV, make sure the TV and Blu-ray or DVD player are switched off.

It is recommended to connect your devices with a HDMI cable (if HDMI port is available) to enjoy better picture and sound quality. For more information about how to connect a Blu-ray or DVD player to your TV, please refer to [Connecting to External Devices > Connecting Audio Visual \(AV\) Devices](#) in this manual.

When the connection is completed, turn on your TV and Blu-ray or DVD player, switch to the input source by pressing the  button, then select the  **Input** icon on Home screen or press the  /  button to change to the port that you connected your Blu-ray or DVD player to.

Connecting USB Devices

Connect USB devices, such as hard drives and USB memory sticks for browsing photos or listening to music.

Read before connecting USB devices

USB disk sizes 4GB, 8GB, 16GB, 32GB, 64GB, 128GB and other common market sizes are supported. Up to 8TB hard drives are supported.

Supported formats: NTFS, FAT32.

Connect USB devices

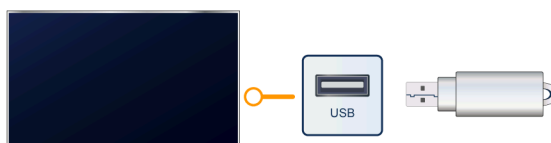

1. Connect USB device to your TV port labeled with USB.
2. Press  button on your remote control and select **Media** from apps.
3. Select the content you want to play or view. For more information, please refer to [Entertainment > Media](#) in this manual.

Precautions when using the USB storage device function

The USB storage device function can be used to record and view digital broadcast programmes.

Read the precautions below before recording or viewing programmes by using the USB storage device function.

Note:

Connecting to External Devices

- Be sure to select the correct country/region for use.
- Use with incorrect settings may violate certain laws or other regulations and may result in criminal punishment. In such cases, our CORPORATION and the Group shall bear no responsibility whatsoever.
- Recorded programmes saved in the USB storage device can only be viewed on this TV. They cannot be viewed when connected to another TV (including the same model of TV), a PC, or other devices.
- Certain digital cameras may not be compatible with the TV.

Connecting Audio Visual (AV) Devices Input Sources

The TV can connect to audio visual devices (including VCR, DVD player or recorder, video camera, Set-Top box, satellite receiver, etc.) with a composite video cable or HDMI cable as input sources.

Connect with a composite video cable

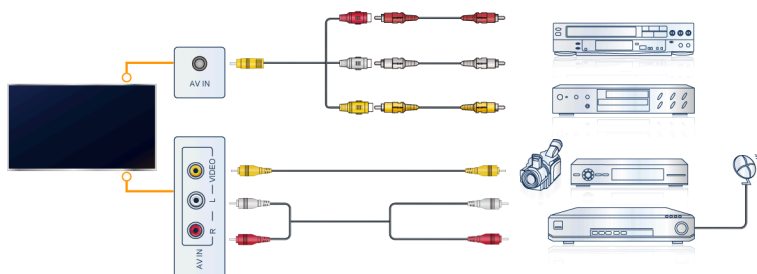

1. Connect an AV device to the TV port labeled with AV IN using a composite video cable (not provided).
2. When the connection is completed, press **INPUT** / **➔** button on your remote control and select **AV** as the input source.

Note:

- AV IN port(s) may vary depending on model type.
- AV IN port(s) may not be available in some models. Please use other port(s) to connect AV devices.
- For some models, RCA Jack to AV cable may not be supplied.

Connect with a HDMI cable

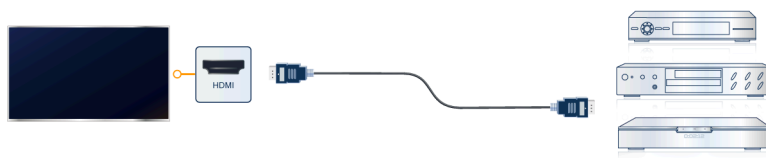

1. Connect an AV device to the TV port labeled with HDMI using a HDMI cable (not provided).
2. When the connection is completed, press **INPUT** / **➔** button on your remote control and select the corresponding HDMI input.

Connecting to External Devices

Note:

- Please refer to the User Manual of your device for step-by-step instructions.
- Some devices, such as DVD players, require the HDMI signal to be set to the correct format in the device settings. Please consult your device user manual for instructions.
- If there is no sound from your TV, configure the device audio settings.

Related information

[Use HDMI & CEC](#) on page 43

Connecting a PC

The TV can connect to a PC to use your TV as a PC monitor.



1. Connect your PC to the TV port labeled with HDMI using a HDMI cable (not provided).
2. When the connection is completed, press **INPUT /** **TV** button on your remote control and select the corresponding HDMI input.

Note:

- For better image quality, set the PC's resolution to a format which is supported by the TV.
- If there is no sound from your TV, change the PC's audio settings.
- If you want to connect your PC and TV wirelessly, please refer to [Connecting to External Devices > Screen Sharing/Content Sharing](#) on the TV in this manual.

Connecting Headphones

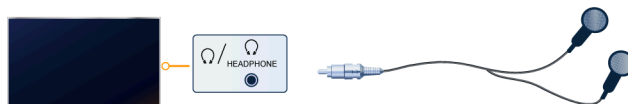

Connect a pair of headphones (not provided) to your TV port labeled with HEADPHONE.

To output sound only with headphones, press **HOME** button on your remote control, select **Settings > Sound > Audio Output**, and choose **Headphone Only**.

Note:



- Headphone port may not be available in some models.
- Headphones with microphones are not supported.

Connecting to External Devices

Connecting Speakers or Other Audio Receivers

The TV can output sound by connecting to speakers, digital sound bars, audio amplifiers, passive bass speakers, etc. with a digital audio cable to enjoy a better listening experience.



1. Connect speakers or other audio receivers to the TV port labeled with DIGITAL AUDIO OUT using a digital audio cable (not provided).
2. Switch on the connected audio device first, then switch on the TV.
3. When the connection is completed, press  button on your remote control, select  **Settings** > **Sound** > **Audio Output** and choose **SPDIF**.





Note:

- If you prefer to use Audio Return Channel (ARC) or enhanced Audio Return Channel (eARC), please refer to [Connecting to External Devices > Connecting a Digital Audio System with ARC/eARC](#) in this manual.

Connecting a Digital Audio System with ARC/eARC

The TV can output sound by connecting to speakers, audio amplifier, digital sound bar, etc. with a HDMI cable to enjoy a better listening experience.



1. Connect digital audio system to the TV port labeled with HDMI ARC/eARC using a HDMI cable (not provided).
2. Power on the audio system.
3. When the connection is completed, the **Audio Output** is automatically switched to **ARC**.
 - If it is not automatically switched to ARC, press  button on your remote control, select  **Settings** > **Sound** > **Audio Output** and choose **ARC**.
 - If the device supports eARC function, press  button and select  **Settings** > **Sound** > **Audio Output Settings** > **HDMI-eARC** and switch **HDMI-eARC** to **On**.

A DVD or Blu-ray player can connect to the TV port labelled with HDMI as a signal input, the TV can connect to an amplifier or sound bar through the TV HDMI ARC/eARC port to output sound at the same time. This is a series connection. HDMI cables are not supplied.



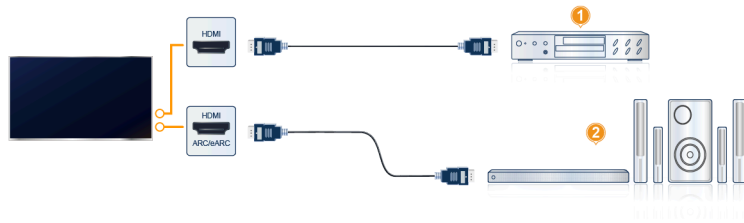

Connecting to External Devices



1 Audio visual devices as input sources

2 Audio system

Note:



- By using this feature, you can also control the sound system with your TV remote instead of using the remote control from the connected device. Enable **CEC Control** by pressing  button on your remote control, then select  **Settings > Connection > HDMI & CEC > CEC Control**.
- To use this feature, audio system must support ARC/eARC function. If it does not support ARC/eARC, you need to connect with DIGITAL AUDIO OUT.
- If the audio system has an Input Selector feature, then make sure to change it to TV.
- Some audio system may not support series connection.
- 5.1 CH (channel) audio is available when the TV is connected to an external device that supports 5.1 channel surround sound. You can press , select  **Settings > Sound > Audio Output Settings > Digital Audio Output Format**, and choose **Dolby Audio - Dolby Digital Plus** to receive the 5.1 channel audio.

Settings Overview

Picture

Adjust picture mode, picture size and other advanced picture settings.

Choose a Picture Mode

Press  button on your remote control and select  **Settings > Picture > Picture Mode**.

Select a pre-set picture mode to best suit the content you are viewing.

Note:

- Options may differ depending on your model/country/region and the content you are watching. Please refer to the specific product.

When you use a normal signal

- **Standard**

Use Standard mode for watching normal content, such as News, Drama or Documentaries.

- **FILMMAKER**

Press  button on your remote control, select  **Settings > Picture > Intelligent Mode Settings > Content Type Auto Detection** to enable Filmmaker mode. When Filmmaker signal is detected, picture mode will turn to **FILMMAKER** automatically.

This function is not applicable in all input sources or applications.

- **Cinema**

Use Cinema for watching movies in a bright environment.

- **Energy Saving**

Energy conservation.

Selecting this mode could reduce power consumption.

- **Dynamic**

Use Dynamic mode for content that requires vivid picture quality.

- **Sports**

Optimised picture for watching sports.

Low Blue Light

Low Blue Light menu on your TV is designed to reduce the level of blue light to protect your eyes.

Press  button on your remote control, select  **Settings > Picture > Picture Mode Settings > Advanced Settings > Colour > Low Blue Light** and select **On**.

To reduce eye strain and protect eyes when you watch TV for a period of time, you are recommended to:

- Take regular and frequent breaks, avoid watching TV for periods of more than one hour. Watching TV for long periods of time may cause eye fatigue.
- Look away from the TV screen and focus on distant objects during viewing breaks for at least 10 minutes.
- Relax yourself during viewing breaks by doing eye exercises or outdoor activities.
- The best recommended viewing distance is 3 times the vertical height of the TV screen.

Regular breaks and exercises are extremely helpful in relieving eye strain and fatigue.

Note:

Settings Overview

- This feature may not be applicable in some models/countries/regions. Low blue light certification may vary by model.



When you use a HDR signal

HDR (high dynamic range) can improve the viewing experience with higher contrast and vivid colours. Bright whites look brighter and dark blacks look darker. TV can display a wide range of colours.

When you use a Dolby Vision signal

Inspired by cinema technology, Dolby Vision is the format that allows your TV to deliver a full range of colours, high dynamic range images, brighter whites and dark blacks using scene-by-scene calibration.

Picture Mode Settings Setup

Press  button on your remote control and select  **Settings > Picture > Picture Mode Settings**.

Adjust display settings for each Picture Mode. You can personalise the picture quality by adjusting the following settings.

Options may not be applicable depending on your model/country/region and the picture mode you selected.

- **Apply Picture Settings**

Select whether the parameters of the current picture mode are applied to all sources or only to the current source.

- **Backlight**

Set the overall luminance of the screen. Please note that changing Picture Settings could increase energy consumption.

Note:

- The function name may vary depending on the model type.

- **Brightness**

Adjust the Brightness level to generate lighter or darker images.

- **Contrast**

Adjust the Contrast level to increase or decrease how bright images appear.

- **Colour Saturation**

Adjust the colour intensity of the picture for a more vibrant image.

- **Sharpness**

Adjust how sharp or soft the edges of images appear.

- **Advanced Settings**

Adjust the colour space and Gamma to best suit the content you are viewing.

- **Reset Current Mode**

Restore all the picture settings in the current picture mode to the factory default values.

Related information

[Picture Issues](#) on page 97

Settings Overview

Advanced Settings Setup

Press  button on your remote control and select  **Settings > Picture > Picture Mode Settings > Advanced Settings**.

Adjust advanced picture settings based on your viewing preference. Adjust the colour space and Gamma to best suit the content you are viewing.

Note:

- Options may not be applicable depending on your model/country/region and the picture mode you selected.

Brightness

• **Dynamic Backlight Control**

Automatically corrects the contrast by analysing the luminance level of the picture in real time.

• **Local Dimming (or Peak Brightness Dynamic Range for some models)**

Optimises contrast by analysing the picture's luminance levels in real time and by automatically adjusting the brightness of each part of the backlight.

• **Peaking Brightness**

Adjust the Peaking Brightness by sections according to the changes in image. This feature is adjustable only when Local dimming is on.

• **Light Sensor settings**

Enable the TV to automatically adjust the picture settings according to the amount of ambient light in your room when **Automatic Light Sensor** is **On**.

Light Sensor Shift is adjustable only when **Automatic Light Sensor** is turned on. If the picture is too bright, decrease the value. If the picture is too dark, increase the value.

Automatically adjust the colour temperature of the TV picture according to the ambient colour temperature when **Automatic Colour Temperature** is **On**.

• **Adaptive Contrast**

Automatically adjust dark areas and light areas of the image to see more detail.

• **HDMI Dynamic Range**

Set the HDMI input signal's dynamic range.

• **Dynamic Tone Mapping**

Automatically adjust brightness and gradient balance by analysing the brightness level of the HDR picture.

• **Dark Detail**

Automatically raise brightness and improve shadow detail in dark scenes.

• **HDR enhancer**

Enhance contrast and colour of the SDR content to HDR-like picture quality.

• **Gamma Adjustment**

Adjust the Gamma to alter how the TV will respond to grayscale content. In low ambient light choose a higher number, in brighter ambient light select a lower number.

• **Gamma Calibration**

Adjust selected Gamma curve.

Settings Overview

Colour

- **Colour Temperature**

Adjust how warm (red) or cool (blue) the white areas of the image appears.

- **Colour Gamut**

Change the range of colours the TV displays.

- **Colour Tuner**

Adjust the Hue, Saturation and Brightness of the colour setting.

- **White Balance**

Adjust the intensity of red, green and blue to view the true colour of all images in the picture.

- **Low Blue Light**

Eye care: reduce the emission of blue light.

Clarity

- **Noise Reduction**

Reduce the random noise to improve the picture quality.

- **Digital Noise Reduction**

Reduce the noise seen around letters and compression noise.

- **Gradient**

Optimise the colour spots of contour lines to deliver better picture quality.

- **Precision Detail**

Automatically enhance image details.

- **Super Resolution**

Super resolution processing technology based on deep learning optimizes the clarity processing effect of the picture.

Motion

- **Ultra Smooth Motion**

Reduce the afterimage effect when viewing fast-moving objects.

- **Clear Motion**

Making fast motion look clearer.

- **High Refresh Rate Mode**

Activate the high refresh rate mode for smoother video while gaming. Please note that the TV picture will be black for a few seconds when enabling this option.

Overscan

Change the video size setting to crop the edges of the displayed image.

Related information

[Picture Issues](#) on page 97

Intelligent Mode Settings

Press  button on your remote control and select  **Settings > Picture > Intelligent Mode Settings**.

Settings Overview

Configure intelligent mode related settings.

- **AI Picture Optimisation**

Set to **On** to enable the TV to recognise the current scene and enhance the picture quality.

- **Content Type Auto Detection**

Enable to detect the content type of Filmmaker Mode or IMAX Mode.

Note:

- Some specific applications have explicit constraints meaning content recognition is not allowed.
- This function may not be applicable in some models/countries/regions.

Change the Aspect Ratio

Press  button on your remote control and select  **Settings > Picture > Aspect Ratio (Picture Size)**.

Adjust the Aspect Ratio to stretch or zoom the picture.

- **Auto**

Automatically switch Aspect Ratio between 16:9 and 4:3 based on the signal information.

- **16:9**

Best suited for 16:9 Widescreen content. This will also stretch 4:3 content to Widescreen.

- **4:3**

Best suited for 4:3 content.

- **21:9**

Best suited for 21:9 content, generally used in game scenarios.

- **Movie Zoom**

Fill the entire screen by zooming in to remove horizontal black bars from the top and bottom of the picture.

- **Dot to Dot**

Displays the native signal without any scaling.



Note:

- The options above may not be applicable in some input sources.
- Using special functions to change the size of the displayed image (e.g. changing the height/width ratio) for the purpose of public display or commercial gain, may infringe on copyright laws.
- If the aspect ratio of the selected format is different from the TV transmission or video content, it can distort the picture.
- When connecting a PC to the TV via HDMI input, fast moving images may become distorted.

Sound

Adjust sound mode and other advanced sound settings.

Choose a Sound Mode

Press  button on your remote control and select  **Settings > Sound > Sound Mode**.

Select a pre-set sound mode to suit the content you are listening to.

Settings Overview

- **Standard**

In Standard mode, the TV delivers a flat frequency response, which preserves the natural characteristics of the original sound.

- **Theatre**

Theatre mode increases the surround sound effect and provides a more prominent bass response.

- **Music**

In Music mode, low and high frequencies are emphasised to enhance musical instrument reproduction.

- **Speech**

In Speech mode, low and high frequencies are attenuated to improve the reproduction and clarity of the human voice.

- **Late Night**

In Late Night mode, the TV will improve the reproduction and clarity of the human voice with a low volume level.

- **Sports**

Optimised sound for watching Sports events.

Sound Mode Settings Setup

Press  button on your remote control and select  **Settings > Sound > Sound Mode Settings**.

Adjust the audio settings of the TV. You can personalise the sound quality by adjusting the following settings.

Options may differ depending on your model/country/region and the content you are watching. Please refer to the specific product.

- **Apply Audio Settings**

Adjust current sound mode to apply to all sources or just the current source.

- **Bass Boost**

Bass Boost uses DTS TruBass™ to enhance the perception of bass frequencies to provide deep, rich bass response from the TV's internal speakers.

- **Surround Sound**

Surround sound uses DTS TruSurround™ to deliver an immersive surround sound experience from the TV's internal speakers.

- **Dialog Clarity**

Dialog Clarity uses DTS Dialog Clarity™ to boost the frequency range of the human voice so dialogue is clearly understood and heard above audio or surround effects.

- **TruVolume**

Automatic control over large volume changes while watching TV programmes or films, providing a more comfortable and consistent volume.



- **Waves**

Based on the psychoacoustic low-frequency extension technology. Waves effectively extend bass response beyond the physical capabilities of the system, presenting a natural, vigorous and strong bass effect.

Settings Overview

- **Equalizer**

Boost the volume at different frequencies.

This function is only applicable when **TV Speaker** is selected at  >  **Settings > Sound > Audio Output**.

- **Wall Mount Setup**

Automatically optimise the sound based on the position of the TV.

- **Auto Volume Control**

Activate to prevent sudden volume changes when switching TV sources.

After **Auto Volume Control** is turned on, it will act as DAP Volume Leveler when playing Dolby Audio, or it will provide DRC function when playing DTS bitstream containing DRC metadata.

- **Reset Current Mode**

Restore all of the audio settings in the current audio mode to the factory default values.



Note:

- Some models may not support decoding of DTS CD bitstreams. Playback of this format may produce undesirable noise.

 **Related information**

[Sound Issues](#) on page 98

Select Speakers

Press  button on your remote control and select  **Settings > Sound > Audio Output**.

Select the speakers which you want to use.

Using External Speakers with TV Speaker to Output Audio

Audio can be played through multiple devices at the same time.





Note:

- This function may not be applicable in some models/countries/regions.



Wired headphones + TV speaker

1. Connect your wired headphones to the TV.
2. Press  button on your remote control to select  **Settings > Sound > Audio Output** to choose **TV Speaker**.



Bluetooth headphones + TV speaker

1. Turn on Bluetooth at  >  **Settings > Connection > Bluetooth**.
2. Pair your Bluetooth headphones with the TV.
3. Press  button on your remote control to select  **Settings > Sound > Audio Output** to choose **TV Speaker**.

Bluetooth speaker + TV speaker

1. Turn on Bluetooth at  >  **Settings > Connection > Bluetooth**.
2. Pair your Bluetooth speaker with the TV.

Settings Overview

3. Set the external device as **BT Headphone** in  **Settings > Connection > Bluetooth > Bluetooth Device > Change Device Type**.
4. Press  button on your remote control to select  **Settings > Sound > Audio Output** to choose **TV Speaker**.

Related information

[Connecting Headphones](#) on page 54

[Connect a Bluetooth Device](#) on page 47

Audio Output Settings Setup

Press  button on your remote control and select  **Settings > Sound > Audio Output Settings**.

Select the digital audio output format that best suits the audio device type.

Options may differ depending on your model/country/region and the Audio Output you select. Please refer to the specific product.

- **Balance**

Adjust the left and right speaker level to optimise audio for a specific location.

- **Lip Sync**

Synchronise the video and audio.

- **Headphone Volume**

Independently adjust the volume of the Headphones.

When **Headphone Only** is selected in **Audio Output**, you can adjust the volume by the remote or in Headphone Volume menu on screen.



When headphones are connected to the TV and **TV Speaker** is selected in **Audio Output**, you can only adjust the volume of headphones in **Headphone Volume** in settings.

- **Digital Audio Output Format**

Select the digital audio output format that best suits the audio device type.

- **Auto**: the audio device automatically outputs in a supported format.
- **Pass Through**: the audio device outputs without any processing.
- **PCM**: the audio device outputs PCM (Pulse Code Modulation) format.
- **Dolby Audio - Dolby Digital**: the audio device outputs Dolby Digital audio.
- **Dolby Audio - Dolby Digital Plus**: the audio device outputs Dolby Digital Plus audio.
- **DTS Surround**: the audio device outputs DTS audio.

Due to the differences between different models, options above may vary according to the actual product.

This function is only applicable when  >  **Settings > Sound > Audio Output** is set to **ARC** or **SPDIF**.

Settings Overview



- **Digital Audio Output Delay**

Adjust the digital audio output delay time to sync audio from an external speaker with the images on the TV.

Note:

- This function is only applicable when  >  **Settings > Sound > Audio Output** is set to **ARC** or **SPDIF**.

- **HDMI-eARC**

You can connect an audio device that supports eARC. Muting occurs temporarily during device connection. This feature is available to set when  >  **Settings > Sound > Audio Output** is set to **ARC**.

- **Dolby Atmos**

Enable **Dolby Atmos** to enhance the richness of sound allowing a more immersive listening experience.

- **Audio Enhancement**

Set **Audio Enhancement** to enjoy the audio performance of Dolby Atmos, DTS Virtual X. Enable or disable according to your own preference. Selections may vary depending on models.

- **Channel Gain**

Bass Boost Gain: Hear and feel rich bass response with the TV's subwoofer speaker.

Top Channel Gain: Experience the rich high-pitched response with the TV's top speaker.

Centre Channel Gain: Experience the rich human voice response with the TV's centre speaker.

 **Related information**



[Connecting Speakers or Other Audio Receivers](#) on page 55

[Connecting a Digital Audio System with ARC/eARC](#) on page 55

Network

You can get access to the Internet through your TV.

Edit TV Name

Press  button on your remote control and select  **Settings > Connection > TV Name**.

You can edit the name for your TV to be used on the network.

Note:

- Up to 18 characters can be entered.

Check the Internet Connection Status

Press  button on your remote control and select  **Settings > Connection > Network > Internet Connection**.

Test the current network connection status and view the current network information.

Connection Test

Press  button on your remote control and select  **Settings > Connection > Network > Internet Connection > Connection Test**.

Settings Overview

Start a network connection test.

Network Information

Press  button on your remote control and select  **Settings > Connection > Network > Internet Connection > Network Information**.

You can select IPv4 or IPv6 in **IP Version** to view more detailed information about your network connection.

Related information

[My TV cannot connect to the network.](#) on page 89

[Connect to a Wired \(Ethernet\) Network](#) on page 7

[Connect to a Wireless Network](#) on page 8

Turn on the TV through the Internet

Wake on Cast

Press  button on your remote control and select  **Settings > Connection > Network > Wake on Cast**.

You can enable or disable Wake on Cast function which is able to turn on the TV by screen casting through mobile devices.

Note:

- This function may not be applicable in some models/countries/regions.
- Enabling this function may result in higher energy consumption.

Wake on Wireless Network

Press  button on your remote control and select  **Settings > Connection > Network > Wake on Wireless Network**.

With a wireless network connection and enabling **Wake on Wireless Network**, you can switch on the TV from standby and push content to be viewed on the TV with a mobile device App supporting the screencast function.

Note:

- To use this function, make sure your TV and mobile device are connected to the same network environment.
- Enabling this function may result in higher energy consumption.
- This function may not be applicable in some models/countries/regions.

Wake on LAN

Press  button on your remote control and select  **Settings > Connection > Network > Wake on LAN**.

With a wired Ethernet connection and enabling **Wake on LAN**, you can switch on the TV from standby and push content to be viewed on the TV with a mobile device App supporting the screencast function.

Note:

- To use this function, make sure your TV and mobile device are connected to the same network environment.
- Enabling this function may result in higher energy consumption.
- This function may not be applicable in some models/countries/regions.

Settings Overview

Related information

[Connect to a Wired \(Ethernet\) Network](#) on page 7

[Connect to a Wireless Network](#) on page 8



System

You can adjust system settings.

Note:

- The menus displayed vary depending on models/countries/regions.

Set Time

Press  button on your remote control and select  **Settings > System > Time**.

Set the current time based on your location.

- **Time Format**

Set the time display to be 12 or 24-hour format.

- **Date/Time**

Set the Date and Time. You can set the date and time to automatically sync with Internet/broadcast or manually setup by yourself.

This function may not be applicable in some models/countries/regions.

- **Time Zone**

Select your time zone.



This function may not be applicable in some models/countries/regions.

- **Daylight Saving**

Select whether to apply Daylight Saving Time to the TV.

This function may not be applicable in some models/countries/regions.

Use Timer

Press  button on your remote control and select  **Settings > System > Timer Settings**.

Adjust the timer settings to suit your preference.

- **Sleep Timer**

Set the sleep timer to automatically turn the TV off at the specified time.

- **Power On Timer**

Set the time you want the TV to turn on automatically.

- **Power Off Timer**

Set the time you want the TV to turn off automatically.

- **Menu Timeout**

Set the amount of time you would like the menu to remain on the screen.

- **Auto Sleep**

Set the amount of time that you would like the TV to auto power off after a period of no activity.

This function may not be applicable in some models/countries/regions.

Settings Overview

- **Auto Standby with No Signal**

TV will go to standby if there is no signal after the set time.

This function may not be applicable in some models/countries/regions.

Set Language and Location

Press  button on your remote control and select  **Settings > System > Language and Location**.

Select the language used for this TV and your location.

- **Location**

Choose the location from where you will watch your TV.

- **Postcode(ZIP/Postal Code)**

User can change the Postcode.

Name of the menu will vary depending on different countries/regions.

This function may not be applicable in some models/countries/regions.

- **Menu Language**

Set the default language for the TV menu.

- **Audio Language**

Select the preferred audio language for the current programme.

Data Protection and Security

Clear Cache

Press  button on your remote control and select  **Settings > System > Application Settings > Clear Cache**.

Clear cache, user data and temporary files for browser and applications.

Delete Cookies

Press  button on your remote control and select  **Settings > System > Application Settings > Delete Cookies**.

Delete cookies for browser and applications.

Do Not Track

Press  button on your remote control and select  **Settings > System > Application Settings > Do Not Track**.

Send a request to websites not to collect or track your browsing data.

Note:

- This function may not be applicable in some models/countries/regions.

Settings Overview

Power on Settings Setup

Auto Init Mode

Press  button on your remote control and select  **Settings > System > Advanced Settings > Auto Init Mode**.

Auto Initialisation Mode. TV will auto initialise in the background when AC is powered on.

Note:

- This function may not be applicable in some models/countries/regions.

Fast Power On

Press  button on your remote control and select  **Settings > System > Advanced Settings > Fast Power On**.

Enable TV fast start-up.

Power On Mode

Press  button on your remote control and select  **Settings > System > Advanced Settings > Power On Mode**.

The TV will turn on in the selected mode when the main power is reconnected.

Default Startup Page

Press  button on your remote control and select  **Settings > System > Advanced Settings > Default Startup Page**.

Set the page that first appears when the TV is powered on. You can select Last Accessed Source or Home.

Power Indicator Mode Setup

Power Indicator

Press  button on your remote control and select  **Settings > System > Advanced Settings > Power Indicator**.

Set the power indicator display to stay On or Off when in Standby mode.

Indicator Light Setting



Press  button on your remote control and select  **Settings > System > Advanced Settings > Indicator Light Setting**.

Set the indicator light from **Power, Always** or **Off**.

Note:

- The above functions may not be applicable in some models/countries/regions.

VIDAA Art setting

To open VIDAA Art setting, press  button on your remote control and select  **Settings > System > Advanced Settings > VIDAA Art setting**.

Settings Overview

Note:

- This function may not be applicable in some models/countries/regions.

Related information

[Using the VIDAA ART](#) on page 36

Switch off Curtain

Press  button on your remote control and select  **Settings > System > Advanced Settings > Switch off Curtain**.

Enable or disable **Switch off Curtain** or set how quickly the Screen Curtain will close when entering standby.



Usage Mode Setup

Press  button on your remote control and select  **Settings > System > Advanced Settings > Usage Mode**.

Set the TV to use in Home or Store mode.

Home Mode





Select Home Mode for normal TV usage.

If you want to switch to Store Mode when the TV is in Home Mode, press  button to select  **Settings**, then select **System > Advanced Settings > Usage Mode** and choose **Store Mode**.

Store Mode

Select Store Mode to setup the TV in a retail setting. This mode enables E-Pos and other demo functions and is only intended for use in retail stores.



When Store Mode is selected, press  /  /  button on your remote control to enter store mode settings.

If you want to switch to Home Mode when the TV is in Store Mode, press  /  /  button on your remote control to enter store mode settings and choose **Home Mode**. Alternatively, press  button, then select  **Settings**, then select **System > Advanced Settings > Usage Mode** and choose **Home Mode**.

Note:

- Enabling Store Mode could increase energy consumption.
- How to exit Store Mode varies depending on models/countries/regions.

Personalised Ads

Press  button on your remote control and select  **Settings > System > Advanced Settings > Personalised Ads**.

Check for personalised ads setting.

• Personalised Ads

Turning off personalised ads will limit the ability to deliver relevant ads to you but will not reduce the number of ads you receive.

Settings Overview

- **Reset Ads ID**

Ads ID is a unique and resettable ID for personalised ads. A new Ads ID will be assigned to your device when you reset it.



Support

You can adjust support settings.

Note:

- The menus displayed vary depending on models/countries/regions.

Check System Info

Press  button on your remote control and select  **Settings > Support > About**.

View system information, like the software version and hardware version.

System Update

Press  button on your remote control and select  **Settings > Support > System Update**.

Set your TV to receive the latest firmware.

- **Auto Update**

When enabled, your device will be updated with the latest software automatically.

Some models doesn't support this function.

- **Check Update**

Check the software version and update if necessary.

Please ensure your TV is connected to the Internet.

- **Check OAD Update**

Check to ensure that your TV has received the latest firmware via the tuner.

Note:

- Please ensure your TV is connected to the Internet.
- This function is only applicable when Thailand and Malaysia are selected in Location.
- **Update from USB**

Upgrade TV software from USB device.

Note:

- Please ensure the USB flash drive is inserted to the USB 2.0 port of the TV.
- The update files must be located in the root directory of the USB device.
- The format of the USB device must be FAT32 and the partition table type must be MBR.

 **Related information**

[Connecting USB Devices](#) on page 52

Enjoy Safe Use of the TV

Press  button on your remote control and select  **Settings > Support > Disclaimer and Privacy > Data Sharing, Privacy and EULA**.

Settings Overview





Read the Disclaimer Details and Data Protection Policy. Allow/Deny your consent to the listed policies relating to the collection of User/Network data.

Press  button on your remote control and select  **Settings > Support > Disclaimer and Privacy > Remove User Data.**

To remove any usage data from the local TV and Cloud storage, select **Remove User Data.**

Check the TV Running Time

You can access the Status Check page to view the running time of your TV.

1. While in an input source, such as Live TV, HDMI or AV, press  /  /  button to launch the quick menu.
2. Under the quick menu, press and hold  [BLUE] button, the Status Check page will appear on screen for you to check the TV running time.

Note:

- This feature may not be applicable in some models/countries/regions.

Panel Maintenance

Note:

This function is only available for OLED models.

Panel Refresh



Perform the panel refresh function to reduce image retention effects.

Due to the optical characteristics of OLED displays, image retention may occur after the TV has been used for an extended period of time. **Panel Refresh** is recommended to correct picture quality issues and prevent image retention.

Do not remove the power plug from the socket when you want to turn off the TV. Please press the power button on the remote to turn the TV off and **Panel Refresh** will be operated automatically when the TV is in standby mode.

The power indicator light will blink when **Panel Refresh** is in progress. The whole progress will be completed within 10 minutes, during the process, the screen will be turned off, once completed the TV will go to standby mode.

You could also choose to manually start **Panel Refresh.**

To manually start **Panel Refresh**, press  button on your remote control and select  **Settings > Support > Panel Maintenance > Panel Refresh.**

Note:

This function is only available for OLED models.

Panel Maintenance

Perform fast maintenance to correct picture quality issues after your TV has been turned on for an extended period of time. This process will be completed within 10 minutes. During the process, the screen will be turned off, please do not disconnect the power to the TV.

Settings Overview

Flashing light indicates panel maintenance in progress. (The colour and position of the flashing light will vary depending on the model.)

If the TV is switched on during the maintenance, the process will be stopped.

You could also choose to manually start **Panel Maintenance**. To manually start this function, press  button on your remote control and select  **Settings > Support > Panel Maintenance > Panel Maintenance**.

Note:

- This function is only available for OLED models.
- Do not touch the display during the maintenance process.

Using Parental Control

Press  button on your remote control and select  **Settings > System > Parental Control**.

Turn on Parental Control to prevent children from being able to view certain content.

If you have not set the PIN code before, create and confirm PIN window will be displayed. Using the D-pad on the remote, create the PIN code.

If you have set the PIN code before, enter PIN window will be displayed.

- **Locks**

Turn on Locks to enable the Parental Control function.

You will see other Parental Control settings change from a greyed out state to highlighted. When this occurs, **Block Time, Channel Block, Content Block, Input Block, App Block, Website Block, Parental Control PIN** or **Reset to Default** features are available to set.

- **Block Time**

Block the whole TV usage for a defined period of time, including Live TV, HDMI and apps.

- **Channel Block**

Block all or individual channels when you turn on the Parental Control feature.

- **Content Block**



Certain programmes are blocked by age rating. This is controlled by the broadcaster.

- **Input Block**

Block content from devices that are connected to external inputs.

- **App Block**

Block access to certain apps. If an app that you want to restrict does not appear here, then check the Parental Control settings in the app.

In some countries/regions, by default, the Browser and the App Store are blocked. If you want to unlock them, please select  **Settings > System > Parental Control** and enter the PIN code. Select the Browser and the App Store in App Block and press  button, then you will find the "lock" icon disappear.

- **Website Block**

Set the range of URLs that the browser can access.

Settings Overview

- **Parental Control PIN**

You can set or change your PIN here. PIN is used for parental control and your system protection from unauthorised use. 0000 is not allowed for PIN.

- **Reset to Default**

Restore Parental Control back to the factory default setting.

Note:

- The above options may not be available in some models/countries/regions.

Reset to Factory Default

Press  button on your remote control and select  **Settings > Support > Reset to Factory Default**.

Restore your TV to the factory default. Reset will clear your personal settings, information and data. Enter the PIN code on-screen to enable the Factory Reset.

Game



Connect your game console or PC and adjust the settings to optimise the TV screen for better gaming entertainment.

- [Play Games with a Gaming Device](#)
- [Play Cloud Games](#)
- [Game Mode](#)
- [Game Menu](#)
- [FreeSync](#)

Play Games with a Gaming Device

Step 1 Connect a Gaming Device







1. Connect your HDMI-supported game console or PC with a HDMI cable to the TV.
2. Switch on your gaming device.
3. Press  /  button. Select the connected gaming device as the input source.

Note:

- When connecting a gaming device that supports 4K 120Hz/144Hz, please connect to the HDMI port that is labeled 4K 120Hz/144Hz or Ultra High Speed on TV.
- The position and type of the HDMI port differs depending on models. Please refer to the printed manual or quick setup guide included with the TV.
- It is recommended to use the HDMI cable included with your gaming device, a Premium High Speed HDMI cable or an Ultra High Speed HDMI cable.

Step 2 Adjust HDMI Format



You can set HDMI Format to enhance the gaming performance.

1. Under HDMI source, press  /  /  button on your remote control to enter quick menu and select **HDMI Format**. Alternatively, press  button on your remote control and select  **Settings > Connection > HDMI & CEC > HDMI Format**.
2. Please select optimal format for the gaming device. For more information, please refer to [Connecting to External Devices > Use HDMI & CEC > HDMI Format function](#) in this manual.

Note:

- The available HDMI format options may vary depending on the model/countries/regions.

Play Cloud Games

1. Connect your TV to a network by pressing the  button on your remote control and selecting  **Settings > Connection > Network > Network Configuration**.
2. Press the  button on your remote control.
3. Select a cloud game app to start the game.

Note:



You can only use gamepad to play cloud games.

Related information

[Control the TV with a Keyboard, Mouse or Gamepad](#) on page 44

Game Mode

You can enable the Game Mode to optimise your TV settings when playing games with a game console, PC or cloud game.

1. Press  button on your remote control and select  **Settings > Picture > Game Settings > Game Mode**.
2. Enable **Game Mode** to optimise the TV settings to enjoy a better gaming experience.



Game Mode will allow:

- Reducing input lag to make sure every press or click matches what is happening on the screen.
- Improving responsiveness to produce very little motion blur.
- Processing YUV 4:4:4 format signals precisely to present accurate image colours.

Note:

- This function may not be applicable in some input sources or applications.

Game Menu

While a gaming device is connected or while using a gaming app, press  /  /  button on your remote control and launch **Game Menu**.

Set the game related settings easily by using the Game Menu. If more than one device is connected, switch to another device quickly by following the on screen menu.

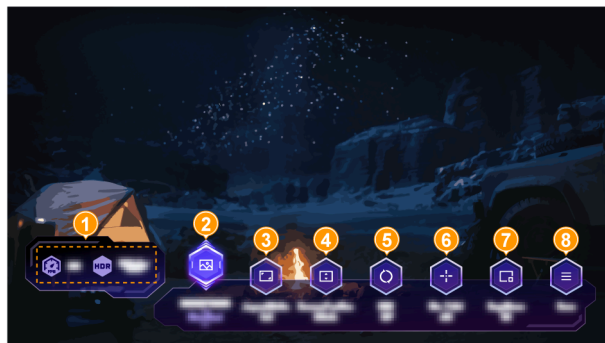

Current status

Entertainment

Check the status, these items cannot be edited.

- **FPS:** Shows the number of frames per second in real time.
- **HDR:** Shows when HDR mode is detected.

2 Game Picture

Select a picture mode to optimise for your game.

3 Screen Ratio

Adjust the aspect ratio according your preference. This feature is only available under HDMI 2.0 or above port and is not applicable in cloud game.

4 Screen Position

You can press up/down button on remote control to move the screen to Top, Middle or Bottom. The position is adjustable when 21:9 or 32:9 is selected in Screen Ratio.

5 AMD FreeSync / AMD FreeSync Premium / AMD FreeSync Premium Pro

Enjoy a smooth viewing experience with external devices connected to the TV when FreeSync is enabled. The menu name will vary depending on your model type.

6 Aim Point

Set the aim point on the screen.

7 Map Zoom

Zoom in on specific areas of the screen when gaming.

8 Menu

Enter the quick menu.

Note:

- The image on your TV may differ from the image above depending on modes/countries/regions.
- Game Menu, and some options of Game menu may vary in some input sources, applications or models.
- Some functions in Game Menu will not be available under certain circumstance.

FreeSync

Press  button on your remote control and select  **Settings > Picture > Game Settings > AMD FreeSync / AMD FreeSync Premium / AMD FreeSync Premium Pro** (the menu name will vary depending on your model type).

Enjoy a smooth viewing experience with external devices connected to the TV when FreeSync is enabled.

Note:

- This function may not be applicable for some HDMI ports.
- This function may not be applicable in some models/countries/regions.



Sports

Sports mode setup in picture or sound settings

Press  button on your remote control and select  **Settings > Picture > Picture Mode > Sports**.

Entertainment

Optimised picture for watching sports.

Press  button on your remote control and select  **Settings > Sound > Sound Mode > Sports**.

Optimised sound for watching sports events.

Sports Mode Auto Detection

Press  button on your remote control and select  **Settings > System > Advanced Settings > Sports Mode Auto Detection**.

When enabled, DTV sports programmes will automatically switch to Sports mode for both Sound Mode and Picture Mode.

Note:

- This function may not be applicable in some models/countries/regions.
- Turning on this function could increase energy consumption.

Media

Press  button on your remote control and select **Media**.

Media is a central location for you to view or listen to different types of content, such as photos, music and movies. You can view media content through the following methods:

- A USB thumb drive or hard drive.
- Compatible mobile phone, tablet or other personal devices: you can stream movies, music and photos that are stored on compatible personal devices and play or view the content on your TV.

By default, there is **Content Sharing** displayed on the Media screen. If your mobile device is connected to the TV, its name also appears on the Media screen.

For more information about **Content Sharing**, please refer to [Benefits of Smart TV > Content Sharing](#) in this manual.

Enjoy Photos/Audio/Video Stored on a USB Device

Press  button on your remote control and select **Media > connected devices**.

Select the content you want to play on the screen, like pictures, videos and music.

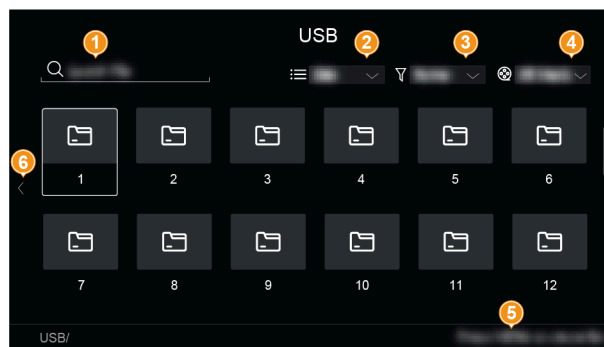

- 1 Search the content you want to play.

Entertainment

- 2 Arrange the content by **Grid, List**.
- 3 Sort the content by **Name, Date Modified, Size**.
- 4 Filter the content by **All Media, Photo, Video, Music, Recorded**.
- 5 Create a photo, music, or video playlist.
- 6 When the focus is on the first row, there will be an arrow on the side. Select the arrow to enter multiple storage sources.

Note:

- Some options in the above table may not be available in some models/countries/regions.
- You must obtain any required permission from copyright owners to download or use copyrighted content. We cannot and do not grant such permission.

Play Background Music while Viewing Pictures

1. Choose a picture to display.
2. Press **▲** / **▼** button to display control bar.
3. Select **🎵** and choose your music to create a Music Playlist.

Now you can play background music while viewing pictures.

Media Format

Due to differences in programming tools and other factors, some of the file formats that are listed may not be supported.

The listed formats may not be supported depending on the model.

Audio Format

Container	File Extension Name
LPCM	.wav
MPEG1/2 Layer1	.mp3
MPEG1/2 Layer2	.wma
MPEG1/2/2.5 Layer3	.flac
WMA	
AAC	
MPEG-H	
FLAC	
VORBIS	
OPUS	

Photo Format

Container	File Extension Name	Mode of Operation	Resolution
JPEG	.jpg .jpeg	baseline	15360 x 8640

Entertainment

Container	File Extension Name	Mode of Operation	Resolution
		progressive	1920 x 1080
PNG	.png	no-interlace	9600 x 6400
		interlace	1200 x 800
BMP	.bmp	-	9600 x 6400
GIF	.gif	-	6400 x 4800

Video Format

Codec Name	File Extension Name	Sampling rate
MPEG1/2	.mp4	1920 x 1080p @ 120fps
MPEG4	.mov	1920 x 1080p @ 60fps
AVC (H.264)	.mkv	4096 x 2160p @ 60fps
HEVC (H.265)	.ts	4096 x 2160p @ 60fps
WMV3	.avi	1920 x 1080p @ 60fps
VC1	.wmv	1920 x 1080p @ 60fps
VP8	.flv	1920 x 1080p @ 60fps
VP9	.webm	4096 x 2160p @ 60fps
AV1		4096 x 2160p @ 60fps

THIS PRODUCT IS LICENSED UNDER THE AVC PATENT PORTFOLIO LICENSE FOR THE PERSONAL USE OF A CONSUMER OR OTHER USES IN WHICH IT DOES NOT RECEIVE REMUNERATION TO (i) ENCODE VIDEO IN COMPLIANCE WITH THE AVC STANDARD ("AVC VIDEO") AND/OR (ii) DECODE AVC VIDEO THAT WAS ENCODED BY A CONSUMER ENGAGED IN A PERSONAL ACTIVITY AND/OR WAS OBTAINED FROM A VIDEO PROVIDER LICENSED TO PROVIDE AVC VIDEO. NO LICENSE IS GRANTED OR SHALL BE IMPLIED FOR ANY OTHER USE. ADDITIONAL INFORMATION MAY BE OBTAINED FROM MPEG LA, L.L.C. SEE [HTTP://WWW.MPEGLA.COM](http://www.mpegla.com)

SoundBar Settings





You can connect a soundbar and change the SoundBar Settings for best device audio quality.

Connect to a soundbar



1. Connect a soundbar device to the TV port labeled with HDMI ARC/eARC.

Entertainment

- When the connection is completed turn on the soundbar, the **Audio Output** is automatically switched to **ARC**. If it is not automatically switched to **ARC**, press  button on your remote control, select  **Settings > Sound > Audio Output** and choose **ARC**.
- Enable **CEC Control** by pressing  button on your remote control, then select  **Settings > Connection > HDMI & CEC > CEC Control**.

Adjust SoundBar Settings

Press  button on your remote control and select  **Settings > Sound > Audio Output Settings > SoundBar Settings**.

- **TV Mode**

Enable TV Mode to allow the connected soundbar to get all the sound modes of TV.

- **EQ Modes**

Choose your favourite EQ mode.

- **Surround Modes**

Enable to turn on the surround effect.

- **Bass Level**

Adjust the bass level.

- **Treble Level**

Adjust the treble level.

- **Dimmer Level**

Adjust the indicator brightness.

- **Reset**

Reset current SoundBar Settings to factory mode.

Note:

- When the connection is successful, a notification will pop up automatically and you can choose to enter the **SoundBar Settings** directly. You can also enter the settings later through the setting menu.
- SoundBar Settings menu is only applicable for the specific soundbar types.
- Options may differ depending on the model type.
- If **Audio Output** is not in **ARC** or the ARC soundbar is not turned on, the SoundBar Settings menu cannot be adjusted, only the TV sound menu can be adjusted.

WiSA Speaker Settings

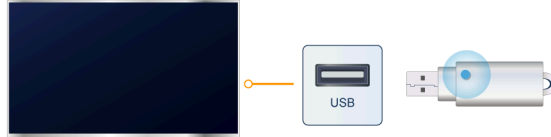

You can connect WiSA speakers and change the WiSA Speaker Settings for the best device audio quality.

Connect to WiSA Speakers



1. Turn on WiSA speakers and insert your WiSA USB transmitter to the TV port labeled USB.
2. After inserting the transmitter, a notification will pop up automatically and you can choose to enter the **WiSA Speaker Settings** directly. You can also enter the settings later through the setting menu.

Note:

- The **Audio Output** is automatically switched to **WiSA Speaker**. If it is not automatically switched, press  button on your remote control, select  **Settings** > **Sound** > **Audio Output** and choose **WiSA Speaker**.
- Only one USB transmitter can be connected to the TV.
- This function may not be applicable in some models/countries/regions.

Adjust WiSA Speaker Settings

Press  button on your remote control and select  **Settings** > **Sound** > **Audio Output Settings** > **WiSA Speaker Settings**.

- **Channel**

Select the channel of WiSA speaker. Selections here may vary depending on model type.

- **Available Speaker List**

Displays the list of speakers that are available. Speaker selection and further changes can be made: select one speaker to play a test tone, set up location selector for different speakers, trim speaker volume and remove a speaker. Some options here will vary depending on the selected Channel.

- **Search Manually**

Search for available speakers manually.

- **Reset WiSA Transmitter**

Reset of the WiSA transmitter configuration information will delete all previous settings.

Note:



- This function may not be applicable in some models/countries/regions.

Karaoke

Note:

Karaoke is only applicable in limited countries/regions.

Connect a microphone to collect audio

1. Connect a microphone to the AV port.
2. Press  button on your remote control and select  **Settings > Connection > Karaoke Mode**, enable **Karaoke Mode**. Then the audio can be collected by the microphone.
3. Open an app on TV or share audio from your mobile device to enjoy Karaoke just at home.

Karaoke mode settings

Press  button on your remote control and select  **Settings > Connection > Karaoke Mode**.

- **Karaoke Mode**

Manually turn on or off Karaoke Mode.

- **Microphone Volume**

Adjust microphone volume. If your microphone support volume up or down, the signal won't sync to Microphone Volume menu on TV.

Note:

- This feature may not be available in some countries/regions/models.

 **Related information**

[Connection Guide](#) on page 42

Accessibility Features

Subtitle Setup

Adjust Subtitle Settings for digital broadcast content.

Press  button on your remote control and select  **Settings > Accessibility > Subtitle Settings.**

- **Subtitle**
Enable Subtitle type.
- **Primary Subtitle**
Set the default subtitle language for digital broadcast content.
- **Secondary Subtitle**
Set the secondary subtitle language for digital broadcast content.
- **Channel Subtitle Storage**
Enable the storage of subtitle settings per channel.

Note:

- The above functions may not be applicable in some models/countries/regions.

Voice Guide

Press  button on your remote control and select  **Settings > Accessibility > Voice Guide.**

Adjust settings for the Menu Audio function.



- **Voice Guide**
Enable or disable Voice Guide.
- **Volume**
Set the Menu Audio volume.
- **Language**
Set the Menu Audio language.
- **Rate**
Set the Menu Audio speed.
- **Pitch**
Set the Menu Audio pitch.
- **Focus Voice Guide**
Turn down the background volume when Menu Audio is playing.

Note:

- This function may not be applicable in some models/countries/regions.

Audio Type Setup

Provide audio description to aid the visually impaired.

Press  button on your remote control and select  **Settings > Accessibility > Audio Type.**

Accessibility Features

- **Audio Type**

Accessibility audio settings.

Note:

In Thailand, you could press AD button (sometimes long press SUBTITLE button to be used as AD button) to select AD mode.

- **Audio Format**

Select the audio format.

- **Fader Control**

Provide the best audio quality options for the visually impaired.

Note:

- The above functions may not be applicable in some models/countries/regions.

Dialogue Enhancement

Press  button on your remote control and select  **Settings > Accessibility > Dialogue Enhancement**.

Enable or disable dialogue enhancement.

Note:

- This function may not be applicable in some models/countries/regions.

Accessibility Menu Setup

Provide menu option to aid the visually or hearing impaired.

High Contrast Menu

Press  button on your remote control and select  **Settings > Accessibility > High Contrast Menu**.

Improve contrast for visually impaired.

Menu Transparency

Press  button on your remote control and select  **Settings > Accessibility > Menu Transparency**.

Select menu transparency from **Off, Medium, High**.

Note:

- The above functions may not be applicable in some models/countries/regions.

Accessible Guide

Press  button on your remote control and select  **Settings > Accessibility > Accessible Guide**.

Accessible guide for visually impaired.

You could select **Off, Freeview Accessible Guide, Large Font Guide**.

Note:

- This function may not be applicable in some models/countries/regions.
- Options in **Accessible Guide** may vary depending on your model.

Accessibility Features

Magnification

Press  button on your remote control and select  **Settings > Accessibility > Magnification**.

Allow visually impaired/partially sighted viewers to magnify an area of the screen.

Note:

- This function is only applicable for some scenarios.
- This function may not be applicable in some models/countries/regions.

Troubleshooting

FAQ

In this section you will find the answers to the most frequently asked questions.

- [There is no picture, or the picture is black and white.](#)
- [There is no sound or the sound is too low at maximum volume.](#)
- [My TV cannot connect to the network.](#)
- [I have connected an external source to my TV but I get no picture and/or sound.](#)
- [The remote control does not work.](#)
- [Schedule Recording cannot be used.](#)

There is no picture, or the picture is black and white.

- Check input cable connections. Incorrect connections may cause colour problems or a blank screen.

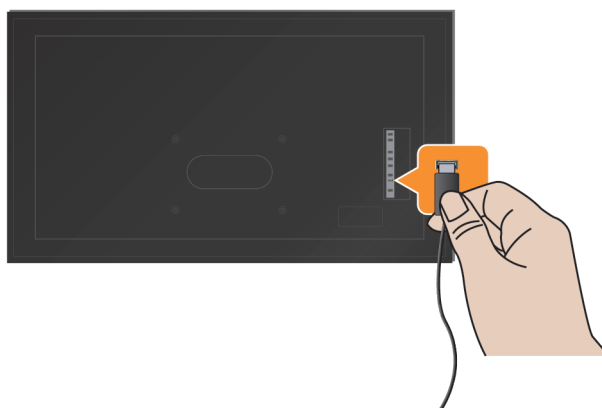

- Make sure that you select the corresponding input source. For example, if you connect HDMI cable to HDMI 1 port, please select HDMI 1 as the input source on TV.
- Check if the **Colour Saturation** is set to 50 or higher at > **Settings > Picture > Picture Mode Settings > Colour Saturation**.
- Press button on your remote control and select **Settings > Picture > Picture Mode Settings > Advanced Settings**. Check and adjust the settings under **Colour** and **Brightness**.
- Switch to other channels or contents to check if the picture colour is normal.
- Unplug the TV power cord from AC outlet and re-plug it after 60 seconds.

Troubleshooting

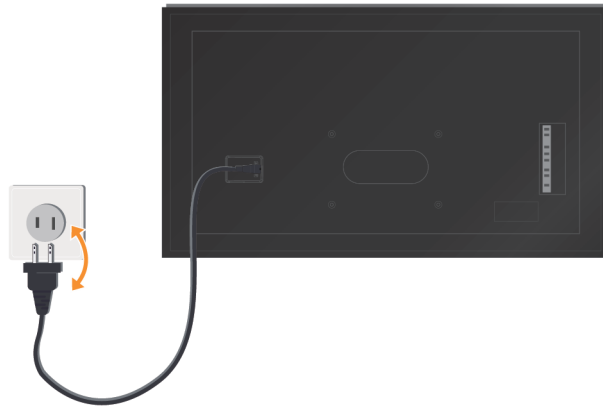

There is no sound or the sound is too low at maximum volume.

- Check if Mute mode is set to **On**. If so, press the mute button on your remote to restore the sound.
- Press volume button on your remote control to check the volume settings.



- Check the volume control of the device (cable or satellite box, DVD, Blu-ray, etc.) connected to your TV.
- Make sure that the audio cable is connected to the correct audio output connector on the external device.
- Check input cable connection to the TV. Incorrect connections may cause no sound.

Troubleshooting

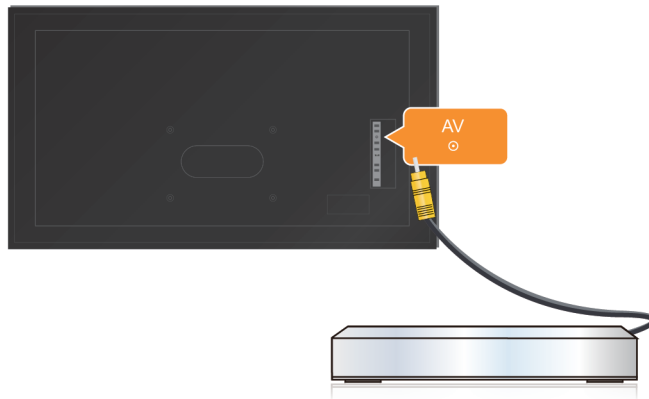

- Make sure that you select the corresponding input source. For example, if you connect HDMI cable to HDMI 1 port, please select HDMI 1 as the input source on TV.
- Check whether **TV Speaker** is selected at **Home** > **Settings** > **Sound** > **Audio Output**.

My TV cannot connect to the network.

Before you review the solutions below, perform self-diagnosis to find the problem.

Press **Home** button on your remote control and select **Settings** > **Support** > **Self Diagnosis** > **Network Connection Test**.

When connected to a wireless network

- Try to connect a wireless network again. Please carefully enter the password, especially for capital and small letters. For specific information please refer to [First-Time Use > Connecting to the Internet > Connect to a Wireless Network](#) in this manual.
- You can connect other wireless devices to the same network. If the connection also fails, contact your Internet service provider.
- You can connect the TV to a wired network. If the wired network connection succeeds, there is an issue with your wireless modem/router.
- Position your wireless router, modem router, or access point close to the TV. Avoid putting it in a corner. As much as possible, make sure there's no wall between the TV and router.

Troubleshooting



- Check whether there is radio wave interference. Wireless devices such as microwaves, mobile phones, operating within the same radio frequency range may interfere with the TV. If you use the TV and other wireless devices simultaneously, you may experience a worse network performance. Please power off these wireless devices or move them further away.
- Restart your modem/router. Power off your modem/router and power it on after at least 60 seconds. It may take time for your modem/router to reconnect to the Internet.
- Check your modem/router. Make sure cables are securely connected to your modem/router and the lights flash intermittently and regularly.

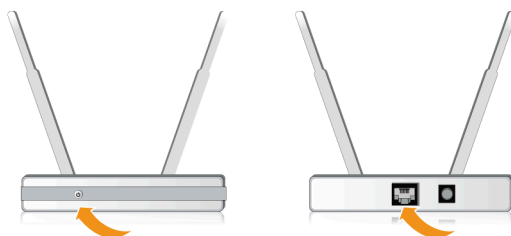

- If the issue is not improved after following the steps above, you can try using a wired network connection. For specific information please refer to [First-Time Use > Connecting to the Internet > Connect to a Wired \(Ethernet\) Network](#) in this manual.

When connected to a wired network

- Press button on your remote control and select **Settings > Connection > Network > Network Configuration**. Press button to enter the submenu. Make sure you choose **Ethernet** in **Connection Type**.
- Restart your modem/router. Power off your modem/router and power it on after at least 60 seconds. It may take time for your modem/router to reconnect to the Internet.
- Check your modem/router. Make sure cables are securely connected to your modem/router and the lights flash intermittently and regularly.
- Make sure one end of the network cable is securely connected on the back of the TV, the other end securely connected to an external modem/router. Any loose connection may cause unstable or disconnected network.

Troubleshooting

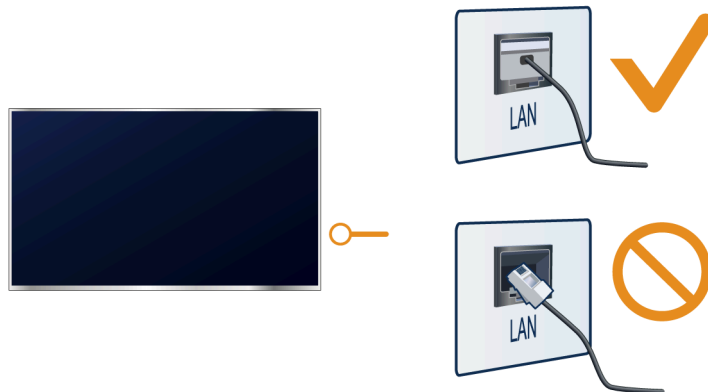

I have connected an external source to my TV but I get no picture and/or sound.

- Check whether the connection between the external device and your TV is correct and secure.

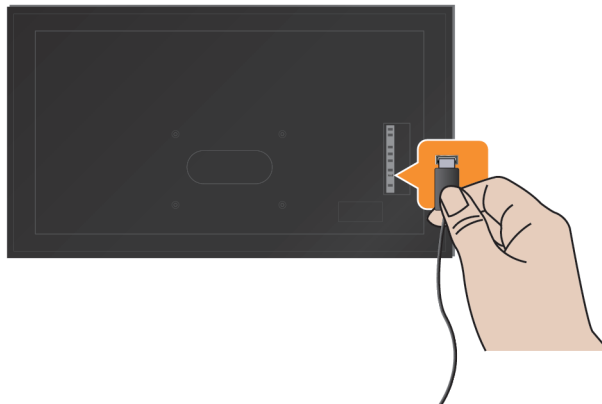

- Make sure that you select the corresponding input source. For example, if you connect HDMI cable to HDMI 1 port, please select HDMI 1 as the input source on TV.
- If the signal is intermittent, unplug the TV power cord from AC outlet and reconnect after 60 seconds.

Troubleshooting

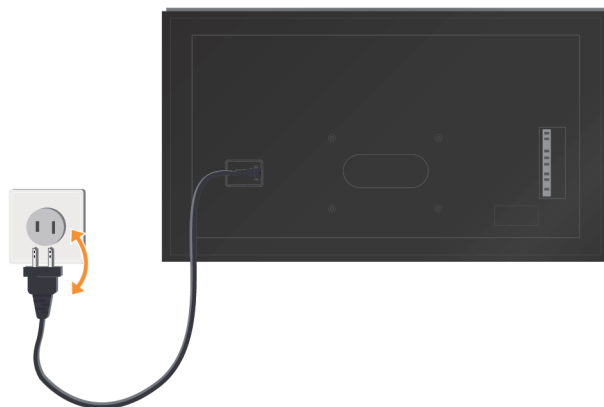

The remote control does not work.

- Confirm that the TV still has power and is operational. Press the power button on the TV to determine if the problem is with the remote control or not.
- Check the indicator on the remote control. (some remote controls do not support this function)

If the TV is not responding to the remote control, then please check if the indicator on the remote control flashes when any button is pressed.

- If the indicator does not flash when the remote control button is pressed, the battery power may be low. You can replace the batteries with new ones. For Solar Powered Remote, you can charge it by exposing the solar panel to light or using a USB type-C cable.

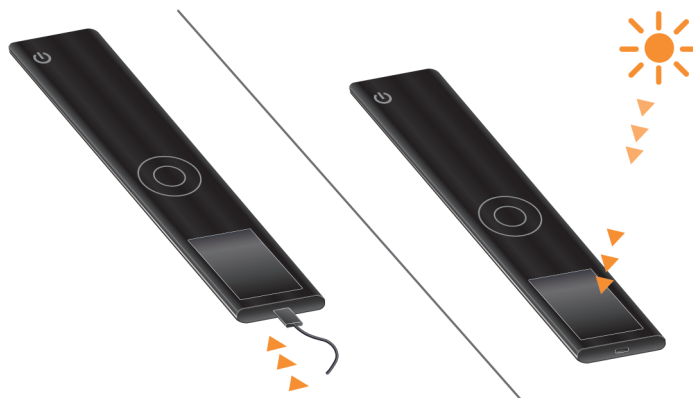





- Check the orientation of each battery. Make sure to match the (+) and (-) ends of the batteries with the (+) and (-) ends indicated in the battery compartment. This method is only applicable for battery-replaceable remote control models.

Troubleshooting

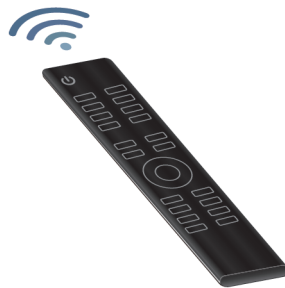
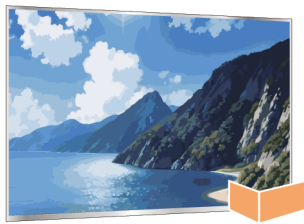

- If the battery power is normal, take out the batteries, press any key for 1~2 seconds, and install batteries back into the remote. This method is only applicable for battery-replaceable remote control models.
- Use the remote control within an appropriate operation range. The remote control can work at a distance of up to 8 meters in front of the TV.
- Keep the TV remote sensor area clear from obstacles. Use the remote control when there are no obstacles between the TV and the remote control.



- If the remote is not working, try to keep interferences such as wireless LAN access point, microwaves, or other Bluetooth devices away when using the remote control.
- For Bluetooth remote controls, try re-pairing the remote control with the TV by pressing and holding the  /  /  button for at least 3 seconds.

Troubleshooting



Schedule Recording cannot be used.

- Check if there is a storage device connected to the TV.



- Check the free space of the storage device. The function will not work if there is not enough storage space on the device.
- Check whether your storage device is damaged. In this case, files cannot be stored. If so, it is suggested to format your storage device.
- Recording will automatically stop if the signal becomes too weak.

Troubleshooting



Note:

- Recording function may not work if the read/write speed of the USB device is too slow.
- Recording function may not work because the storage format of your device is unsupported.
- The Recording functions may not be applicable in some models/countries/regions.

Troubleshooting Guide

Please first try the following steps to resolve the issues:

- [Perform the status diagnosis](#)
- [Check whether the TV has updated the latest software](#)
- [Restart or reset the TV](#)

If the issue persists, select the following issues below to start troubleshooting:

 [Picture Issues](#)

 [Sound Issues](#)

 [Channel and Broadcast Issues](#)

 [Network Issues](#)

 [App Issues](#)

 [Remote Control Issues](#)

 [External Device Connection Issues](#)

 [HDMI & CEC Issues](#)

 [Voice Service Issues](#)

 [Media Files Issues](#)

 [Other Issues](#)

If the solutions do not help you resolve the issues, please contact our service centre.

Status Diagnosis

When the TV malfunctions, you can perform self-diagnosis to find the problem.

Picture Test

Press  button on your remote control and select  **Settings** > **Support** > **Self Diagnosis** > **Picture Test**.

Troubleshooting

When performing the Picture Test, a test picture will be shown on screen. Select OK to start the test. Picture Test displays a high-definition picture that you can examine for flaws or faults. Please check the picture carefully for up to 10 seconds.

Find more specific solutions in [Troubleshooting > Picture Issues](#) in this manual.



Sound Test

Press  button on your remote control and select  **Settings > Support > Self Diagnosis > Sound Test**.

When performing the Sound Test, a test sound will be played with the TV Speaker. Select OK to start the test. Please listen to the sound carefully to check whether you can hear the sound problem.

Find more specific solutions in [Troubleshooting > Sound Issues](#) in this manual.

Network Related Self-diagnosis

Press  button on your remote control and select  **Settings > Support > Self Diagnosis**.

- **Network Connection Status**

View the TV's network connection information.

- **Network Connection Test**

When performing a Network Connection Test, the test will confirm whether your TV is connected to network. If the network test is successful but you still have problems using online services, please contact your Internet provider.

- **Internet Speed Test**

Perform this test to check the network speed.

Find more specific solutions in [Troubleshooting > Network Issues](#) in this manual.



Input Connection Test

Press  button on your remote control and select  **Settings > Support > Self Diagnosis > Input Connection Test**.

When performing an Input Connection Test, you can select any of the input sources and check related information with external connections.

Find more specific solutions in [Troubleshooting > Channel and Broadcast Issues](#) and [Troubleshooting > External Device Connection Issues](#) in this manual.

Status Check

Press  button on your remote control and select  **Settings > Support > Self Diagnosis > Status Check**.

When performing a Status Check, the status of your TV will be displayed showing any error codes.

Signal Info

Press  button on your remote control and select  **Settings > Support > Self Diagnosis > Signal Info**.

Show the signal information of current input.

Find more specific solutions in [Troubleshooting > Channel and Broadcast Issues](#) and [Troubleshooting > External Device Connection Issues](#) in this manual.

Troubleshooting

Restart or reset your TV

If the TV has problems such as a delay between the picture and sound or connection fails to external devices, you can try to restart your TV first to troubleshoot the issue. If the problems persist, reset your TV to the factory default. Before you start, remove any external USB devices from the TV.

Restart your TV

1. Press the power button on your remote control or press the power button on the TV to turn it off. For some models, press the power button on the TV to display the on-screen menu, and press the button again to move the focus to **Power off** to turn off the TV.
2. Unplug the TV power cord from AC outlet and reconnect after 60 seconds.
3. Press the power button on your remote control or press the power button on the TV to turn it on.

Note:

- Restart your TV will not clear your personal settings, information and data.

Reset your TV

Please note that reset will clear your personal settings, information and data. Find more specific operation steps in [Settings Overview > Reset to Factory Default](#) in this manual.

Remote Control Service

Press  button on your remote control and select  **Settings > Support > Remote Control Service**.

Remote Control Service enables your TV to be controlled from the client server to allow service agents to diagnose the problem of your TV and deal with the problem online efficiently.

To use this function:

1. Turn on **Remote Control Service**.
2. Select **Agree All** and **Confirm** in End User License Agreement page.
3. Select **Generate PIN** in Remote Control Service.
4. You can initiate a help request to a service agent by the hotline and provide the on-screen PIN.

Note:

- This function may not be applicable in some models/countries/regions.
- Steps above may vary. Please refer to the specific product.
- Keep the network connected when the Remote Control Service is running.

Picture Issues





Before you review the problems and solutions below, use **Picture Test** to perform self-diagnosis to find the problem. For specific information please refer to [Troubleshooting > Troubleshooting Guide > Status Diagnosis > Picture Test](#) in this manual. If the test picture does not appear or you find your screen damaged, contact the service centre in your country/region.

If the test picture is displayed properly, please check the items below.

- [The picture is distorted, blurry or flickering, or cuts out momentarily.](#)
- [There are dots, horizontal or vertical lines on the screen.](#)
- [The brightness cannot be adjusted.](#)

Troubleshooting

? The picture is distorted, blurry or flickering, or cuts out momentarily.

- Press  button on your remote control and select  **Settings > Picture > Picture Mode Settings > Sharpness** to adjust **Sharpness**.
- Press  button on your remote control and select  **Settings > Picture > Picture Mode Settings > Advanced Settings > Clarity/Motion** to adjust **Clarity/Motion** settings.
- Make sure that the connection cable or the cable connector is not damaged.
- Make sure that the connection cable is securely connected to the TV and the external device.
- Some electrical appliances may affect the TV. For example, microwave ovens close to the TV may cause noise on analogue and digital channels. If you turn off the appliance and the interference stops, please move it further away from your TV.
- If you choose **TV** as the input source, adjust the direction and position of the aerial, reset or fine tune the channel.
- When connecting the TV to external devices, leave some space between the external devices and the TV.





Note:

- Picture distortion caused by weak or poor signal reception is not a TV malfunction.
- The compressed video may cause picture distortion, especially for the fast moving pictures from sports programmes and action movies.

? There are dots, horizontal or vertical lines on the screen.

- Switch to other channels or contents to check if the picture is normal.
- Change the output resolution of your external device. When the TV is not compatible with the output resolution, dots or lines may occur.
- Check if the TV is located in a humid space for a long time. It is suggested to use the TV in a relatively dry environment.
- Some electrical appliances may affect the TV. For example, microwave ovens close to the TV may cause noise on analogue and digital channels. If you turn off the appliance and the interference stops, please move it further away from your TV.

? The brightness cannot be adjusted.

- Check Light Sensor settings at  >  **Settings > Picture > Picture Mode Settings > Advanced Settings > Brightness**. If **Automatic Light Sensor** is on, remove the objects that may block the TV light sensor.
- Turn off **Automatic Light Sensor**. Press  button on your remote control and select  **Settings > Picture > Picture Mode Settings > Advanced Settings > Brightness > Light Sensor settings** to adjust the setting.

Note:

- The light sensor feature settings may not be applicable in some models/countries/regions.

Sound Issues





Before you review the problems and solutions below, use **Sound Test** to perform self-diagnosis to find the problem. For specific information please refer to [Troubleshooting > Troubleshooting Guide > Status Diagnosis > Sound Test](#) in this manual.

Troubleshooting

Please check the items below.

- [There is a delay between the picture and sound.](#)
- [Sound is distorted or cuts out momentarily.](#)
- [Volume cannot be changed or it changes on its own.](#)

⓪ There is a delay between the picture and sound.

- Press  button on your remote control and select  **Settings > Sound > Audio Output Settings > Digital Audio Output Delay**. Set the value to 0.
- Press  button on your remote control and select  **Settings > Sound > Audio Output Settings > Lip Sync**. Adjust the value as you desire.
- Check the signal information. If the signal is weak or poor, a delay between the picture and sound may occur but it is not a malfunction. For specific information please refer to [Troubleshooting > Troubleshooting Guide > Status Diagnosis > Network Related Self-diagnosis](#) and [Input Connection Test](#) in this manual.





Note:

- Options may not be applicable depending on your model/country/region and the Audio Output you select. Please refer to the specific product.

⓪ Sound is distorted or cuts out momentarily.

- Some electrical appliances may affect the TV. For example, microwave ovens close to the TV may cause noise on analogue and digital channels. If you turn off the appliance and the interference stops, please move it further away from your TV.
- Make sure that the connection cable or the cable connector is not damaged.
- If you use an external audio output device, make sure that the audio cable is connected to the correct audio output connector on the external device. Place the device as close as possible to the TV without any obstacles between them.
- Check the signal Information. A weak or poor signal may cause sound distortion, but it is not a malfunction. For specific information please refer to [Troubleshooting > Troubleshooting Guide > Status Diagnosis > Network Related Self-diagnosis](#) and [Signal Info](#) in this manual.

⓪ Volume cannot be changed or it changes on its own.

- Press the power button on the TV to check if the TV responds. If there is no response, the TV may not be normally working. If the TV responds, press the remote control to check if it can control the TV. If not, please check the remote control. For specific information please refer to [Troubleshooting > Remote Control Issues](#) in this manual.
- Check if **Auto Volume Control** is turned on at  >  **Settings > Sound > Sound Mode Settings**.
- When connecting an external speaker via HDMI, first check the cable connection, then press  button on your remote control and select  **Settings > Connection > HDMI & CEC > CEC Control**, set **CEC Control** to **On**.
- Insufficient TV memory causes a lag when you change the volume. Please clear cache.
- If you have just turned on the TV, there may exist a delay after you press the volume up/down button on the remote control. Please wait a while for the TV to start up fully.
- If the problem persists, [restart your TV](#).

Troubleshooting



Channel and Broadcast Issues

Before you review the problems and solutions below, use **Input Connection Test** to perform self-diagnosis to find the problem. For specific information please refer to [Troubleshooting > Troubleshooting Guide > Status Diagnosis > Input Connection Test](#) in this manual.





Please check the items below.

- [In Live TV, there is no signal, or a weak signal, or you cannot find any channels.](#)
- [The subtitles are not displaying or are in the wrong place on the TV screen.](#)
- [The channel list sorting is lost after several days, or previously deleted channels return in the channel list.](#)
- [I want to put channels in order of preference.](#)

❓ **In Live TV, there is no signal, or a weak signal, or you cannot find any channels.**

- Please check the following things first.
 - a. The cable or cable connector of the aerial is not damaged.
 - b. The aerial cable is not loose or disconnected.
 - c. The aerial cable is connected to the correct port.
 - d. "TV" is selected as the input source.
- If no signal or weak signal occasionally happens, disconnect the aerial cable and reconnect it.
- If you use a set-top box or cable box, check the broadcast signals or the network status that is connected to the external device. For specific information please refer to [Troubleshooting > Troubleshooting Guide > Status Diagnosis > Network Related Self-diagnosis](#) and [Input Connection Test](#) in this manual.
- If the problem persists, scan channels again. In Live TV, press  button on your remote control and select  **Settings > Channel > Auto Scan/Advanced Settings > Manual Scan**. For specific information please refer to [Enjoy Live TV > Channel Scan](#) in this manual.

❓ **The subtitles are not displaying or are in the wrong place on the TV screen.**

- To turn on/off the subtitle function, press  /  /  button on your remote control and select **Subtitle** when in TV input source. Or press  button on your remote control and select  **Settings > Accessibility > Subtitle Settings**. For specific information please refer to [Accessibility Features > Subtitle Setup](#) in this manual.
- If you are watching a channel through an external device such as a set-top box and cable box, turn on/off the subtitle function on the external device and adjust the subtitle location on screen. For more information, refer to the user manual of external device or contact your service provider.

Note:

- Some channels may not have subtitle data. In this case, even if you turn on the subtitle function, subtitles are not provided on TV screen.

Troubleshooting

② The channel list sorting is lost after several days, or previously deleted channels return in the channel list.

- Make sure that you have not reset the TV to factory default before. Resetting the TV will reset all your user settings.
- Check if the channels in the channel list have updated or your subscription expires.
- Re-scan channels to find lost channels in your channel list. For specific information please refer to [Enjoy Live TV > Channel Scan](#) in this manual.

② I want to put channels in order of preference.

- You can edit the order of channels to your preference or you can add channels that you like to the favourite list. For specific information please refer to [Enjoy Live TV > Channel Edit > Edit Channel List](#) or [Edit Favourite Channel List](#) in this manual.

Network Issues

Before you review the problems and solutions below, perform self-diagnosis to find the problem. For specific information please refer to [Troubleshooting > Troubleshooting Guide > Status Diagnosis > Network Related Self-diagnosis](#) in this manual.

Please check the items below.

- [The signal strength is weak.](#)
- [The network connection is unstable, often disconnected.](#)

② The signal strength is weak.

- See Number 1, 2, 3, 6 in [Common solutions to network issues.](#)

② The network connection is unstable, often disconnected.

When connected to a wireless network

- See Number 1, 2, 3, 4, 6 in [Common solutions to network issues.](#)

When connected to a wired network

- See Number 3, 4, 5 in [Common solutions to network issues.](#)

Common solutions to network issues

1. Position your wireless router, modem router, or access point close to the TV. Avoid putting it in a corner. As much as possible, make sure there is no wall between the TV and router.
2. Check whether there is radio wave interference. Wireless devices such as microwaves, mobile phones, operating within the same radio frequency range may interfere with the TV. If you use the TV and other wireless devices simultaneously, you may experience a worse network performance. Please power off these wireless devices or keep them away from the TV.
3. Restart your modem/router. Power off your modem/router and power it on again after at least 60 seconds. It may take time for your modem/router to reconnect to the Internet.
4. Check your modem/router. Make sure cables are securely connected to your modem/router and the lights flash intermittently and regularly.

Troubleshooting

5. Make sure one end of the network cable is securely connected on the back of the TV, the other end securely connected to an external modem/router. Any loose connection may cause unstable or disconnected network.
6. If the issue is not improved after following the steps above, you can try using a wired network connection. For specific information please refer to [First-Time Use > Connecting to the Internet > Connect to a Wired \(Ethernet\) Network](#) in this manual.

App Issues

Please check the items below.

- [Apps cannot be installed, opened, updated or uninstalled.](#)
- [The app exits itself.](#)
- [The app is frozen or navigation is not smooth while using.](#)
- [Problems occur when using the Browser to stream videos.](#)
- [The app language is different from the TV menu language.](#)

❓ **Apps cannot be installed, opened, updated or uninstalled.**

- If you have just turned on the TV, please wait until the TV start up is complete.
- You can only install apps that are compatible with the TV. We recommend to [install apps from the app store](#). The apk files downloaded from the Internet may not be installed on the TV.
- You can only delete apps that you have installed to the TV. Factory-installed apps cannot be deleted.
- See Number 1, 2, 3 in [Common solutions to app issues](#).

❓ **The app exits itself.**

- See Number 2 in [Common solutions to app issues](#).

❓ **The app is frozen or navigation is not smooth while using.**

- Exit the app and then open it again.
- Uninstall and reinstall the app. For specific information please refer to [Benefits of Smart TV > Using Apps](#) in this manual.
- See Number 1, 2, 3 in [Common solutions to app issues](#).

❓ **Problems occur when using the Browser to stream videos.**

- Exit the Browser and then open it again.
- See Number 1, 2 in [Common solutions to app issues](#).

❓ **The app language is different from the TV menu language.**

- The language in an app could be different from the TV menu language because they may be separately set up. You can change the language in the app settings. Please note that whether you can change the language in an app depends on the app service provider.

Common solutions to app issues

1. Check [whether your TV is connected to the Internet](#) and whether there are [network issues](#) with your TV.

Troubleshooting

2. The storage is insufficient. Try to [clear cache](#) or uninstall uncommonly used apps. You can clear cache for browser and apps. This will permanently remove all the user data and temporary files.
3. The service of the app may not be available currently. Try using apps later.

Remote Control Issues

Please check the items below.



- [The TV is slow to respond to the remote control.](#)
- [I want to use the remote control to control other devices.](#)

❓ The TV is slow to respond to the remote control.

When the TV has just started, the response delay may occur between the TV and remote control. Please wait a while to use the remote control.

- The battery power of the remote control may be low. You can replace the batteries with new ones. For Solar Powered Remote, you can charge by exposing the solar panel to light or using a USB type-C cable.
- If the battery power is normal, take out the batteries, press any key for 1~2 seconds, then reinstall batteries back into the remote. This method is only applicable for battery-replaceable remote control models.

❓ I want to use the remote control to control other devices.

- Turn on **CEC Control** on the TV. Press  button on your remote control and select  **Settings > Connection > HDMI & CEC > CEC Control**.
- Confirm that the external device is HDMI & CEC compatible and the HDMI & CEC feature of the connected device is turned on. For specific information, please refer to the user manual with the external device.
- Check whether the power cable of the external device is properly connected and the HDMI cable connection between the external device and the TV is secure. Please use a HDMI cable of standard specification and make sure the cable is not damaged.

External Device Connection Issues

Before you review the problems and solutions below, use **Input Connection Test** to perform self-diagnosis to find the problem. For specific information please refer to [Troubleshooting > Troubleshooting Guide > Status Diagnosis > Input Connection Test](#) in this manual.



Please check the items below.

- [No sound from the TV while using the casting feature.](#)
- [I cannot mirror the screen or cast the content of my mobile device or PC on the TV.](#)
- [The TV cannot be connected to my soundbar, Bluetooth wireless headphones or speakers.](#)
- [Connection between external devices and the TV is unstable.](#)
- [I cannot select a connected device or find a connected HDMI device.](#)
- [I want to output sound from headphones and TV speakers, or from Bluetooth speaker and TV speakers at the same time.](#)





❓ No sound from the TV while using the casting feature.

- Check if Mute mode is set to **On**. If so, press the mute button on your remote to restore the sound. If not, turn up the volume.

Troubleshooting

- Check if **TV Speaker** is selected at  >  **Settings > Sound > Audio Output**.
- Check the network status. If the network signal is weak or low, there may exist a sound delay between the TV and the mobile device. For specific information please refer to [Troubleshooting > Network Issues](#) in this manual.

I cannot mirror the screen or cast the content of my mobile device or PC on the TV.

- Check if your TV supports **Screen Sharing/Content Sharing** in input sources.
- For iPhone, iPad, or Mac, use AirPlay to share content on the TV. Check if your TV supports **AirPlay** at  >  **Settings > Connection > AirPlay and HomeKit**. Some TV models may not support AirPlay.
- Check if **Content Sharing** is turned on at  >  **Settings > Connection > Mobile Device Connection > Content Sharing** and switch it to **On**.
- Make sure that the TV and the mobile device are connected to the same network.
- Check if the content that you are playing is copyrighted. Some copyrighted files may not be cast to the TV.
- Check the network status. Casting failure may result from weak or low signal strength. For specific information please refer to [Troubleshooting > Network Issues](#) in this manual.
- Exit and re-enter **Screen Sharing/Content Sharing** in case that there is a software bug.



The TV cannot be connected to my soundbar, Bluetooth wireless headphones or speakers.

- Check if the Bluetooth device is compatible with the TV.
- Check if connection cable or cable connector is damaged.
- Check if the Bluetooth is turned on at  >  **Settings > Connection > Bluetooth**.
- Turn off and restart Bluetooth at  >  **Settings > Connection > Bluetooth**.

Connection between external devices and the TV is unstable.







- Check if the connection cable is securely connected to the TV and soundbar.
- When the external device and the TV are connected via wireless, make sure that there are no obstacles between them.
- Make sure that the distance between the Bluetooth device and the TV is within 10 metres.
- Check if the Bluetooth device is powered on or its battery is fully charged.
- Check Bluetooth module specifications. Make sure that the frequency range of Bluetooth devices is not the same as other electric appliances, otherwise Bluetooth devices may be affected.

I cannot select a connected device or find a connected HDMI device.

- Press  /  button on your remote control to select the corresponding input source. For example, if you connect HDMI cable to HDMI 1 port, please select HDMI 1 as the input source on TV.
- Check if the external device is powered on.
- Check if connection cable or cable connector is damaged.
- Check if the cable is securely connected.
- Check if the external device is compatible with the TV.

Troubleshooting

? I want to output sound from headphones and TV speakers, or from Bluetooth speaker and TV speakers at the same time.

- If you connect wired headphones to the TV, press  button on your remote control to select  **Settings** > **Sound** > **Audio Output** to choose **TV Speaker**.
- If you want to connect Bluetooth headphones/Bluetooth speaker to the TV:
 - a. Turn on Bluetooth at  >  **Settings** > **Connection** > **Bluetooth**.
 - b. Connect your Bluetooth headphones/Bluetooth speaker and set the external device as **BT Headphone** in  **Settings** > **Connection** > **Bluetooth** > **Bluetooth Device** > **Change Device Type**.
 - c. Press  button on your remote control, select  **Settings** > **Sound** > **Audio Output** to choose **TV Speaker**.

HDMI & CEC Issues

Please check the items below.

- [I want to turn the TV and external device off or on at the same time.](#)
- [I want to disable HDMI & CEC function.](#)
- [An external device cannot be controlled by using the TV remote control.](#)



Note:

- If the connected HDMI device does not support HDMI & CEC control, the feature will not work.



? I want to turn the TV and external device off or on at the same time.

- Confirm that the external device is HDMI & CEC compatible and the HDMI & CEC feature of the connected device is turned on. For specific information, please refer to the user manual with the external device.
- Check whether HDMI & CEC feature of your TV is turned on or device auto power off and device auto power on are enabled. For specific information please refer to [Connecting to External Devices > Remote & Accessories > Use HDMI & CEC](#) in this manual.

? I want to disable HDMI & CEC function.

- To turn off the HDMI & CEC feature of your TV, press  button on your remote control and select  **Settings** > **Connection** > **HDMI & CEC** > **CEC Control**. Set **CEC Control** to **Off**.

? An external device cannot be controlled by using the TV remote control.

- Check whether there is an issue with your remote control. For specific information please refer to [Troubleshooting > Remote Control Issues](#) in this manual.
- Check whether the power cable of the external device is properly connected and the HDMI cable connection between the external device and the TV is secure. Please use a HDMI cable of standard specification and make sure the cable is not damaged.
- Confirm that the external device is HDMI & CEC compatible and the HDMI & CEC feature of the connected device is turned on. For specific information, please refer to the user manual with the external device.
- Check whether HDMI & CEC feature of your TV is turned on. Press  button on your remote control and select  **Settings** > **Connection** > **HDMI & CEC** > **CEC Control**. Set **CEC Control** to **On**.

Troubleshooting

- Some menus of the HDMI & CEC compatible device may not be available for use.
- Some buttons on the remote control may not work. You can try the external device remote control.

Voice Service Issues

Please check the items below.

- [Voice button on remote control does not work.](#)
- [The TV fails to receive voice commands. Wake-up words were spoken, but there is no answer.](#)



Before you perform the following solutions, please note that:

- Make sure your TV is turned on. The TV cannot respond in standby mode.
- If you have just turned on the TV, please wait a while until the TV start up is complete.
- Your voice should be clear and recognisable. If the voice is too loud or too low, this may result in a failure.
- Please say your command and wait for the device to respond.
- When the TV is connected with external devices, the performance of the voice service may be affected.

❓ Voice button on remote control does not work.

- Check the status of your remote control. For specific information please refer to [Troubleshooting > Remote Control Issues](#) in this manual.
- Keep the remote control within 3 metres from the TV.
- Check [whether your TV is connected to the Internet](#). A low or weak signal may result in a failure of the voice assistant.
- Change account or log out of the account.

❓ The TV fails to receive voice commands. Wake-up words were spoken, but there is no answer.

- Check whether the built-in microphone control button at the bottom of the TV is switched on.
- Check [whether your TV is connected to the Internet](#). A low or weak signal may result in a failure of the voice assistant.
- After the Voice Assistant setup has been completed, check whether the Hands-Free mode is turned on. Press  button, select the  **Settings** icon, then select **System > Voice Service** to find the menu.
- Wake-up words may differ depending on Voice Assistant. For specific information please refer to [First-Time Use > Using the TV Voice Service > Hands-Free Wake-up](#) in this manual.
- When the TV is far from you or the ambient noise is loud, the TV may not receive the voice command accurately.
- Change account or log out of the account.

Note:

- The Hands-Free Wake-up and some of its features are available on limited country/region/language.

Media Files Issues

❓ Some files are interrupted during playback or cannot be played.

Most files can be played back, but you might experience problems with the TV or the files.

Troubleshooting

- First check if there are problems with files.
 - a. The files are not corrupted. After you have saved files to a storage device (a USB flash drive) from PC, please eject the storage device first before you disconnect it from the PC.
 - b. The format of files that can be played depends on the codec and driver of the TV. For example, high-bitrate or high-resolution files may not be played back smoothly or cannot be played. For more information about the supported codecs, please refer to [Entertainment > Media](#) in this manual.
- Then check if there are problems with TV.
 - a. Make sure the memory is sufficient. If the memory is full, [clear cache](#) and play the file again.
 - b. Make sure the cable connected to the TV and the external device is not loose or disconnected.

Other Issues

Please check the items below.

- [The TV automatically turns on or off by itself, or the TV cannot be turned on or off.](#)
- [System update cannot be completed.](#)
- [Some features of the TV do not work after the system update.](#)
- [The settings are lost and need to be reconfigured every time the TV is turned on.](#)
- [I want to sign out my account or delete account usage data.](#)
- [The TV is hot.](#)
- [I can hear the voice-over of the TV on-screen menu or contents.](#)

❓ **The TV automatically turns on or off by itself, or the TV cannot be turned on or off.**



When the TV is performing certain operations, such as Remove User Data or Reset to Factory Default, the TV will restart by itself. This is normal.

Turns off by itself

- Check if the power cord is connected to AC outlet. Disconnection will let the TV shut down.
- Check if **Sleep Timer**, **Power Off Timer** or **Auto Sleep** is set. These features will help the TV to automatically turn off at the specified time.

Press  button on your remote control and select  **Settings > System > Timer Settings**. Please find these features in **Timer Settings**.

- Check if **Auto Standby with No Signal** is set. If current input has no signal and you do not interact with the TV, the TV will enter the standby mode.





Press  button on your remote control and select  **Settings > System > Timer Settings > Auto Standby with No Signal**. This function may not be applicable in some models/countries/regions.

- Check if **CEC Control** is enabled. When CEC control is enabled and HDMI & CEC compatible external devices are turned off, the TV will enter the standby mode.

Press  button on your remote control and select  **Settings > Connection > HDMI & CEC > CEC Control**.

Turns on by itself

Troubleshooting

- Check if **Power On Timer** is enabled. This feature will help the TV to automatically turn on.
Press  button on your remote control and select  **Settings > System > Timer Settings > Power On Timer**.
- Check if **TV Auto Power On** is enabled. This feature will help the TV to automatically turn on when HDMI & CEC compatible external devices are turned on.
Press  button on your remote control and select  **Settings > Connection > HDMI & CEC > TV Auto Power On**.

Cannot be turned on

- Check if the power cord is connected to AC outlet. You can unplug the TV power cord from AC outlet and reconnect it after 60 seconds.
- Try to turn on the TV with the remote control. Press the power button on the remote control and check if the TV turns on. If you cannot turn on the TV with the remote control, please refer to [Troubleshooting > Remote Control Issues](#) in this manual to troubleshoot.
- Try to turn on the TV with the power button on the TV. Press the power button and check if the TV turns on.

Cannot be turned off

- When the TV cannot be turned off with the remote control, the remote control may not work. Please refer to [Troubleshooting > Remote Control Issues](#) in this manual to troubleshoot.
- Try to press the power button on the TV to turn it off. For some models, press the power button on the TV to display the on-screen menu, and press the button again to move the focus to **Power off** to turn off the TV.
- If the TV cannot be turned off by pressing the power button on the TV, disconnect the power cord from the AC outlet.

System update cannot be completed.

The software update takes a couple of minutes. Please wait a while.

- Check [whether your TV is connected to the Internet](#) and whether there are [network issues](#) with your TV. Try to upgrade again when network issues are fixed.
- [Restart your TV](#) then try to perform system update.
- If the issue persists, you can upgrade the software using a USB drive. For specific information please refer to [Settings Overview > Support > System Update](#) in this manual.

Some features of the TV do not work after the system update.

- See [Troubleshooting > Troubleshooting Guide > Restart or reset your TV](#) in this manual.

The settings are lost and need to be reconfigured every time the TV is turned on.



- Make sure that you did not perform a factory reset of the TV. Factory reset will erase all the settings.
- Make sure that you did not remove the user data. This operation will clear relative settings.
- Make sure that the TV is not in store mode. When the TV is in store mode, TV settings will be reset every few minutes.
- Check if you have updated the software recently. The system may be unstable after the TV is upgraded.

Troubleshooting

- When you turn off the TV, some settings will be automatically switched off.

❓ I want to sign out my account or delete account usage data.

To sign out my account

1. Press  button on your remote control and select  **Account** in the navigation bar on the Home screen.
2. Choose the account that you want to sign out, select **Account Settings > Sign Out**, and the account will be removed from the TV.

The following situations will help automatically sign out your account:

- Switch from store mode to home mode
- Change the location settings
- Unselect **Agree to VIDAA Account** in **Data Sharing, Privacy and EULA**
- Restore your TV to the factory default and remove user data

To delete account usage data

Press  button on your remote control and select  **Settings > Support > Disclaimer and Privacy > Remove User Data**.



Note:

- This setting will completely delete your usage data (including account, Live TV favourite channel list, Bluetooth equipment management information, TV name, etc.) and the data cannot be restored.
- The TV will restart after you confirm to clear data.

❓ The TV is hot.

- This is normal because the panel generates heat when you use the TV for a period of time, but the heat does not affect the TV functionality. As long as the TV runs normally, you do not need to worry.
- We recommend that you place the TV in a properly ventilated location for good air circulation.
- When the TV is in standby mode, you may also feel the heat because the TV may be under Standby Recording.

❓ I can hear the voice-over of the TV on-screen menu or contents.

- The voice-over is due to the enabling of Voice Guide. To turn off Voice Guide, press  button on your remote control and select  **Settings > Accessibility > Voice Guide** and turn **Voice Guide** off. This function may not be applicable in some models/countries/regions.